

CODE NUMBER

12001004

DESCRIPTION

SU-1209 Urinal and GEM-2 186 Flushometer.

COMPONENTS

- Flushometer: Code 3072619
- Urinal: Code 1101209

DETAILS

- Flush Volume: 0.125 gpf (0.5 Lpf)
- Nominal Dimensions: 14 ½" x 20 ¾" x 25 ¼" (368 x 527 x 641mm)

FLUSHOMETER FEATURES

- Fixed Volume Piston with Filtered O-ring Bypass
- ADA Compliant Metal Oscillating Non-Hold-Open Handle
- ¾" I.P.S. Screwdriver Bak-Chek® Angle Stop with Control Stop Plug
- Vacuum Breaker Flush Connection
- Spud Coupling, Wall and Spud Flanges for ¾" Top Spud
- Cast Wall Flange with Set Screw
- Sweat Solder Adapter with Cover Tube
- Non-Hold-Open Handle and No External Volume Adjustment to Ensure Water Conservation
- Handle Packing, Stop Seat and Vacuum Breaker Molded from PERMEX® Rubber Compound for Chloramine Resistance

FIXTURE FEATURES

- White Vitreous China
- Large footprint to cover old caulk lines
- Washdown flushing action
- Integral flushing rim
- ¾" I.P.S. top spud inlet
- 2" NPT outlet flange
- Vandal resistant strainer assembly included
- All mounting hardware included
- 100% factory flush tested



COMPLIANCES & CERTIFICATIONS



(ADA Compliant, BAA Compliant, BREEAM Water Credit, CalGreen Compliant, CEC Compliant, cUPC Green Certified, EPD, Green Globes Water Credit, HPD, LEED Materials & Resources EPD Credit, LEED Materials & Resources HPD Credit, LEED V4 Water Efficiency Credit, Satisfies LEED Credits, WELL Building Standard)

DOWNLOADS

- [Retrofit Urinal Installation Instructions](#)
- [GEM/GEM 2 Piston Type Exposed Installation Instructions](#)
- [SS/ST/SU/WETS/WEUS Fixtures Repair and Maintenance Guide](#)
- [Additional Downloads](#)

NOTES

All information contained within this document subject to change without notice.

WARRANTY

[View Warranty Information](#)

ROUGH-IN

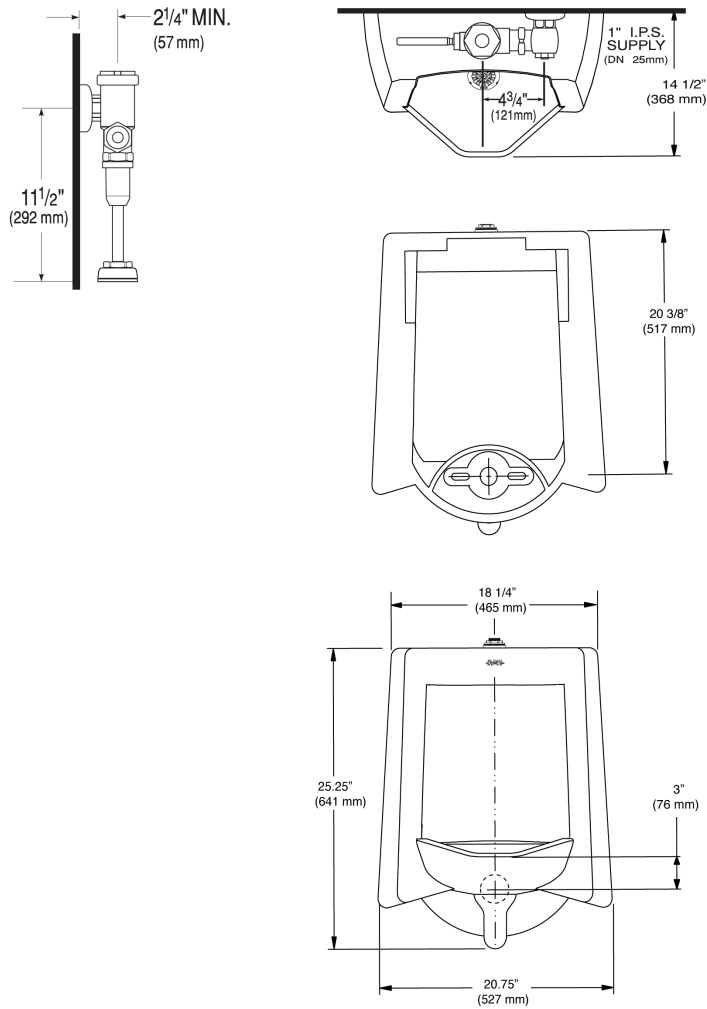

Sloan 10500 Seymour Ave, Franklin Park, IL 60131
 Phone: 800.982.5839 • Fax: 800.447.8329 • sloan.com