

## DROPSOT™ CANE APRON INSTALLATION INSTRUCTIONS

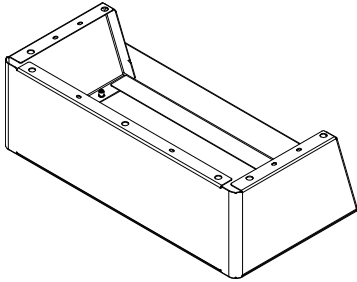

### 33830030

BFS-16 Cane Apron – Stainless Steel  
for DRS-120

### 33830031

BFS-17 Cane Apron – Black  
for DRS-120

### SLOAN® LIMITED WARRANTY SUMMARY

Sloan Valve Company ("Sloan"), warrants its products against defects in materials and workmanship, excluding damage caused by matters beyond Sloan's reasonable control. Instructions for filing claims can be found in the Limited Warranty which can be obtained at [www.sloan.com](http://www.sloan.com) or by requesting a free copy by telephone at 888.756.2614. Sloan will repair or replace your defective product, or provide a refund, as your exclusive remedy. This is only a general summary of Sloan's Limited Warranty so it is important to note that the specific terms, conditions, limitations and exclusions, including the duration of warranty coverage for your particular Sloan product, are contained in the actual Sloan Limited Warranty. The Limited Warranty is subject to applicable laws in your country, state, province or other jurisdiction—and disputes arising under the Limited Warranty are to be resolved by binding arbitration unless you provide Sloan with an opt-out notice no later than 30 days after your purchase date. In case of a conflict with this summary, the terms and conditions set forth in the complete Limited Warranty will prevail.

**TOOLS REQUIRED BUT NOT PROVIDED:** 1/8" and 5/32" hex driver or Allen wrench

- 1 Use a 1/8" hex driver or Allen wrench to remove the six (6) screws from the bottom of the cane apron that retain the bottom cover. Set bottom cover and screws aside for later use.

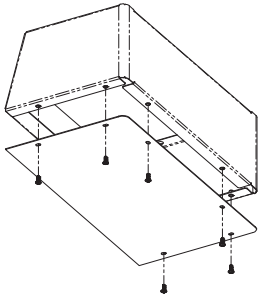

- 2 Fit the cane apron to the bottom apron of the high-side unit.

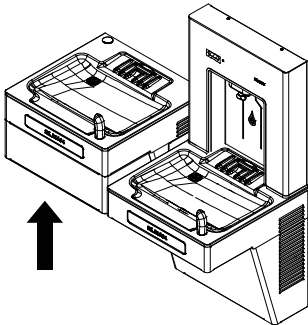

- 3 Use a 5/32" hex driver or Allen key and the other provided six (6) screws to secure the cane apron via the slotted holes into the high-side apron.

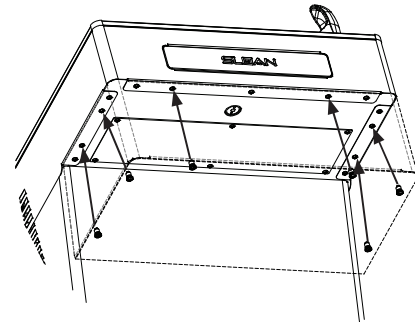

- 4 If the high-side fountain has a drop-down filter kit installed, the installation is complete. Discard or save the bottom cover in the event the drop-down filter kit is removed.
- 5 If the high-side fountain does not have a drop-down filter kit installed, then reverse Step 1 to secure the bottom cover to the cane apron.

**When assistance is required, please contact Sloan  
Technical Support at 1.888.SLOAN.14 or 1.888.756.2614.**

The information contained in this document is subject to change without notice.

**SLOAN • 10500 SEYMOUR AVENUE • FRANKLIN PARK, IL 60131**

Phone: +1.800.9.VALVE.9 or +1.800.982.5839 • Fax: +1.800.447.8329 • [www.sloan.com](http://www.sloan.com)