

## Concealed Flushometer (Royal®)

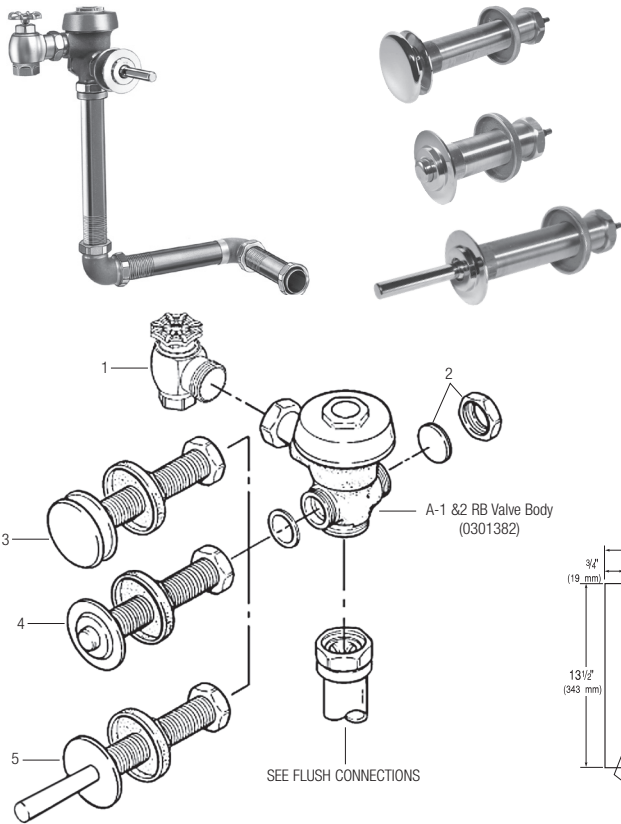

### TAILPIECES, CONTROL STOPS, FLUSH CONNECTIONS AND HANDLE ASSEMBLIES

For additional information on tailpieces, control stops, flush connections, and handle assemblies see Showerheads, Parts and Accessories Tab.

#### PARTS LIST

Item No.	Code No.	Part No.	Description
1.	<b>0388010</b>	H-730-A	1" RB Wheel Handle Bak-Chek® Control Stop
	<b>0388011</b>	H-730-A	3/4" RB Wheel Handle Bak-Chek® Control Stop
2.	<b>3301093</b>	A-1013-A	Concealed Valve Handle Cap Kit
<b>FOR SPECIFYING PROPER LENGTHS FOR ITEMS 3, 4 AND 5, SEE CHART BELOW</b>			
3.	—	C-43-A	3" (76 mm) Push Button Actuator Assembly
4.	—	C-9-A	Blind Nut Push Button Actuator Assembly
5.	—	B-12-A	Lever Actuator Assembly
6.	—	C-43-AWB	Wall Box Push Button Assembly
7.	—	C-9-A WB	Wall Button Push Button Actuator Assembly
8.	—	B-12-AWB	Wall Box Lever Actuator Assembly (Not Shown)

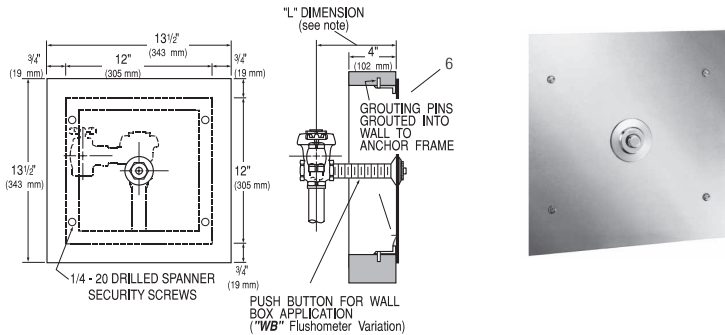

Specify the "L" dimension for the proper length of the push button assembly

"L" dimension PUSH BUTTON ID CHART (all dimensions in inches)

Wall Thickness	1	2	3	4	5	6	7	8	9	10	11	12	13	14	15
"L" Dimension	3 3/4	4 3/4	5 3/4	6 3/4	7 3/4	8 3/4	9 3/4	10 3/4	11 3/4	12 3/4	13 3/4	14 3/4	15 3/4	16 3/4	17 3/4
"A" (B-15-A) Filler Rod	1 5/8	2 5/8	3 5/8	4 5/8	5 5/8	6 5/8	7 5/8	8 5/8	9 5/8	10 5/8	11 5/8	12 5/8	13v5/8	14 5/8	15 5/8
"B" (B-6-A) Socket Assembly	2 1/2	3 1/2	4 1/2	5 1/2	6 1/2	7 1/2	8 1/2	9 1/2	10 1/2	11 1/2	12 1/2	13 1/2	14 1/2	15 1/2	16 1/2

Notes: 1. "L" Dimension = Wall thickness (to nearest whole inch) + 2 3/4"  
 2. 1 1/2" Diameter Hole Opening Required Through Wall

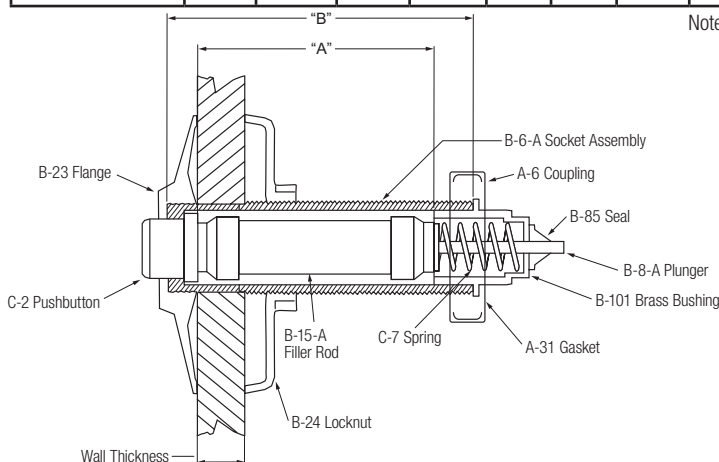

## Concealed Flushometer (Royal®)

### TROUBLESHOOTING GUIDE

**ATTENTION INSTALLERS:** With the exception of the control stop inlet, **DO NOT USE** pipe sealant or plumbing grease on any valve component or coupling! To protect the chrome or special finish of Sloan flushometers, **DO NOT USE** toothed tools to install or service these valves. Use our A-50 Super Wrench or other smooth-jawed wrench to secure couplings. Regulations for low consumption fixtures (1.6 gpf/6.0 Lpf closets and 1.0 gpf/3.8 Lpf urinals) prohibit use of higher flush volumes.

#### 1. Flushometer DOES NOT function.

- Control stop or main valve is closed. Open control stop or main valve.
- Handle or push button assembly is worn. Install Sloan handle repair kit (C-70-A) or replace handle or push button.
- Relief valve is worn. Replace inside parts kit.

#### 2. Insufficient volume of water to adequately siphon fixture.

- Control stop not open enough. Adjust control stop for desired delivery of water.
- Urinal flushometer parts inside a closet flushometer. Replace inside urinal parts with proper closet flushometer Parts.
- Low consumption flushometer installed on a non-low consumption fixture. Replace A-41-A inside parts kit with A-38-A water saver kit.
- Water saver kit installed in old, non-water saver bowl. Position refill head A-170 so that SIDE 1 is in the UP position.
- Inadequate volume or pressure at supply.
  - If no gauges are available to properly measure supply pressure or volume of water at the flushometer, then remove the relief valve from the inside parts kit, reassemble the flushometer and open the control stop. If the fixture siphons, more water volume is required. If a 3.5 gpf inside parts kit is installed in the flushometer, then first flip the refill head (under the diaphragm) to obtain a 4.5 gpf volume. If this volume is still inadequate, remove the flow ring from the guide to obtain a 6.5 gpf kit. If additional flow is still required, try a low pressure guide kit A-175-A (#0301104).

**IMPORTANT: Laws and regulation prohibit the use of higher flushing volumes than listed on fixture or flushometer.**

  - If fixture **DOES NOT** siphon or if a low consumption fixture is installed, or if the above steps do not prove satisfactory, steps must be taken to increase the pressure and/or supply.

#### 3. Flushometer closes off immediately.

- Ruptured or damaged diaphragm. Install inside parts kit to correct problem and update flushometer.
- Enlarged bypass orifice from corrosion or damage. Install inside parts kit to correct problem and update flushometer.

#### 4. Length of flush is too short (short flushing).

- Diaphragm assembly and guide assembly are not hand-tight. Screw the two assemblies hand-tight.
- Enlarged bypass orifice from corrosion or damage. Install NEW inside parts kit to correct problem and update flushometer.
- A-19-AU (Black) urinal relief valve in closet flushometer. Replace relief valve with A-19-AC (White) closet relief valve.
- A-41-A low consumption kit installed in non-low consumption fixture. Replace with proper Inside Parts Kit.
- Handle assembly is worn. Install handle repair kit (C-70-A) or replace the handle.

#### 5. Length of flush is too long (Long Flushing) or fails to close off.

- Relief valve is not seating properly or bypass orifice is clogged because of foreign material, or bypass orifice is closed by an invisible gelatinous film from "over-treated" water. Disassemble the working parts and wash thoroughly. NOTE: SIZE OF ORIFICE IN THE BYPASS IS EXTREMELY IMPORTANT FOR PROPER METERING OF WATER INTO THE UPPER CHAMBER OF THE FLUSHOMETER. DO NOT ENLARGE OR DAMAGE THIS ORIFICE. REPLACE INSIDE KIT IF CLEANING DOES NOT CORRECT PROBLEM.
- Line pressure has dropped and is not sufficient to force relief valve to seat. Shut off all control stops until pressure has been restored, then open them again.
- A-19-AC (White) closet relief valve has been used in a 1.0 or 1.5 gpf urinal. Replace with A-19-AU (Black) relief valve.
- Inside cover is cracked or damaged. Replace the inside cover (A-71).

#### 6. Chattering noise in flushometer.

- The A-156-A segment diaphragm has been installed upside-down. Replace the segment diaphragm to the proper position as instructed by markings on the diaphragm.
- The inside cover has become distorted from wear, freezing or abuse. Replace inside cover.

#### 7. Leaking at handle or push button assembly.

- The B-39 Seal is worn or deteriorated. Install new B-39 seal. NOTE: The B-39 Seal will easily slide onto the B-40 Bushing if it is wet.
- Handle gasket has been omitted. Install A-31 handle gasket or Sloan handle repair kit (C-70-A).
- Valve handle bushing is worn. Install Sloan handle repair kit (C-70-A).

### CARE AND CLEANING INSTRUCTIONS

**DO NOT USE** abrasive or chemical cleaners (including chlorine bleach) to clean flushometers that may dull the luster and attack the chrome or special decorative finishes. Use **ONLY** mild soap and water, then wipe dry with a clean towel or cloth.

While cleaning the bathroom tile, protect the flushometer from any splattering of cleaner. Acids and cleaning fluids will discolor or remove chrome plating.

**When assistance is required, please contact Sloan Technical Support at: 1-888-SLOAN-14 (1-888-756-2614).**