

## INSTALLATION INSTRUCTIONS FOR STAINLESS STEEL WATER CLOSETS, AND COMBINATION FIXTURES

### Concealed Flushometer with Push Button Actuator

**Flushometer**  
**1½" (38 mm) Back Inlet**  
MODEL 8603-ESM



**8603-2.4** ESM-HW A04 2act 5m60mLO  
**8603-1.6** ESM-HW A04 2act 5m60mLO  
**8603-1.28** ESM-HW A04 2act 5m60mLO  
**8603-2.4** ESM-HW A05 Dorm  
**8603-1.28** ESM-HW A05 Dorm  
**8603-1.6** ESM-HW A05 Dorm

### LIMITED WARRANTY

Unless otherwise noted, Sloan Valve Company warrants this product, manufactured and sold for commercial or industrial uses, to be free from defects in material and workmanship for a period of three (3) years (one (1) year for special finishes, SF faucets, PWT electronics and 30 days for PWT software) from date of first purchase. During this period, Sloan Valve Company will, at its option, repair, replace, or refund the purchase price of any product which fails to conform with this warranty under normal use and service. This shall be the sole and exclusive remedy under this warranty. Products must be returned to Sloan Valve Company, at customer's cost. No claims will be allowed for labor, transportation or other costs. This warranty extends only to persons or organizations who purchase Sloan Valve Company's products directly from Sloan Valve Company for purpose of resale. This warranty does not cover the life of the batteries.

**THERE ARE NO WARRANTIES WHICH EXTEND BEYOND THE DESCRIPTION ON THE FACE HEREOF. IN NO EVENT IS SLOAN VALVE COMPANY RESPONSIBLE FOR ANY CONSEQUENTIAL DAMAGES OF ANY MEASURE WHATSOEVER.**

### PRIOR TO INSTALLATION

Prior to installing the Sloan Flushometer, perform the following functions using the rough-in diagrams on Pages 2 and 3.

- Bore a 1-1/2" (38 mm) opening in wall for pushbutton actuator.
- Bore a 1-2" (25-51 mm) opening in wall for piping. Refer to the Rough-in drawings on Pages 2 and 3. (This is **NOT** required if wall sleeve is used in conjunction with fixture.)
- Install stainless steel fixture.
- Install drain line.
- Install water supply line.

#### IMPORTANT:

- **INSTALL ALL PLUMBING IN ACCORDANCE WITH APPLICABLE CODES AND REGULATIONS.**
- **WATER SUPPLY LINES MUST BE SIZED TO PROVIDE AN ADEQUATE VOLUME OF WATER FOR EACH FIXTURE.**
- **FLUSH ALL WATER LINES PRIOR TO MAKING CONNECTIONS.**

Sloan's flushometers are designed to operate with 15 to 80 psi (103 to 552 kPa) of water pressure. **THE MINIMUM PRESSURE REQUIRED BY THE VALVE IS DETERMINED BY THE TYPE OF FIXTURE SELECTED.**

Consult fixture manufacturer for minimum pressure requirements. Most Low Consumption water closets (1.6 gpf/6.0 Lpf) require a minimum flowing pressure of 25 psi (172 kPa).

### TOOLS REQUIRED FOR INSTALLATION

- Standard set of hex wrenches
- Sloan A-50 Super-Wrench™, Sloan A-109 Plier Wrench or smooth jawed spud wrench
- Strap Wrench & Hacksaw

# ROUGH-INS

## MODEL 8603 – WATER CLOSET

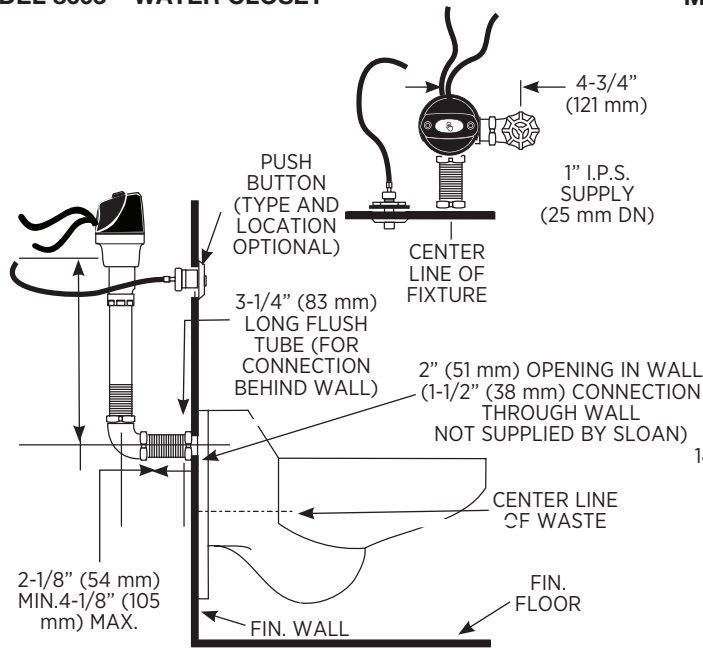

## MODEL 8603 – COMBINATION FIXTURE

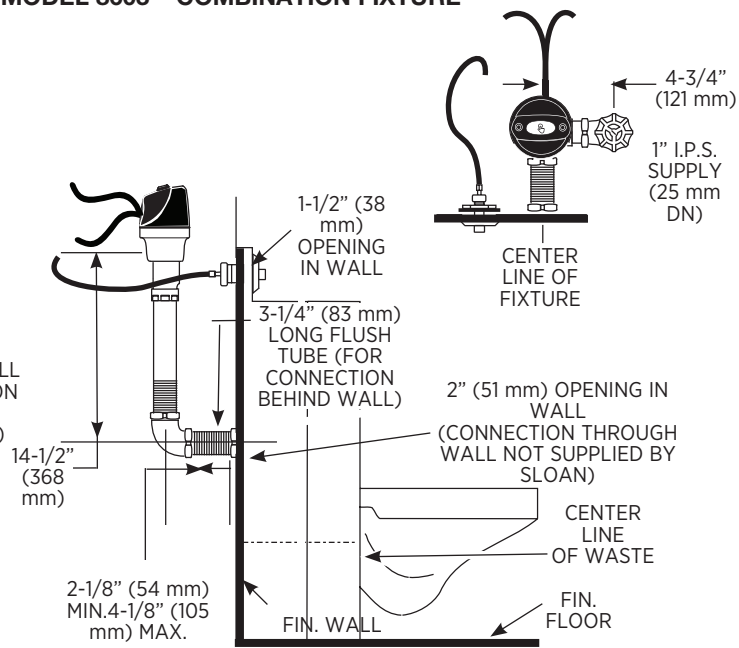

**!!! IMPORTANT !!!**

NEVER OPEN THE CONTROL STOP TO WHERE THE FLOW FROM THE VALVE EXCEEDS THE FLOW CAPABILITY OF THE FIXTURE. IN THE EVENT OF A VALVE FAILURE, THE FIXTURE MUST BE ABLE TO ACCOMMODATE A CONTINUOUS FLOW FROM THE VALVE.

**!!! IMPORTANT !!!**

WITH THE EXCEPTION OF CONTROL STOP INLET, DO NOT USE PIPE SEALANT OR PLUMBING GREASE ON ANY VALVE COMPONENT OR COUPLING!

**!!! IMPORTANT !!!**

DUE TO THE HIGH BACK PRESSURES THAT CAN BE CREATED BY STAINLESS WATER CLOSETS AND COMBINATION FIXTURES, THE FOLLOWING PROCEDURES MUST BE FOLLOWED WHEN INSTALLING THE FLUSH CONNECTIONS. FAILURE TO FOLLOW THESE PROCEDURES CAN RESULT IN SEPARATIONS.

**!!! IMPORTANT !!!**

ONLY USE LOCTITE WHEN INDICATED IN THIS MANUAL. ONLY USE THE LOCTITE SUPPLIED BY SLOAN.

**!!! IMPORTANT !!!**

THIS PRODUCT CONTAINS MECHANICAL AND/OR ELECTRICAL COMPONENTS THAT ARE SUBJECT TO NORMAL WEAR. THESE COMPONENTS SHOULD BE CHECKED ON A REGULAR BASIS AND REPLACED AS NEEDED TO MAINTAIN THE VALVE'S PERFORMANCE.

**!!! IMPORTANT !!!**

PROTECT THE CHROME OR SPECIAL FINISH OF SLOAN FLUSHOMETERS. DO NOT USE TOOTHED TOOLS TO INSTALL OR SERVICE VALVES. USE A SLOAN A-50 SUPER WRENCH™ OR SMOOTH JAWED SPUD WRENCH TO SECURE COUPLINGS. SEE "CARE AND CLEANING" SECTION OF THIS MANUAL.

## 1 - INSTALL OPTIONAL SWEAT SOLDER ADAPTER (ONLY IF SUPPLY PIPE DOES NOT HAVE MALE THREAD) AND INSTALL CONTROL STOP

- A** For Sweat Solder applications, slide Threaded Adapter onto water supply pipe until end of pipe rests against shoulder of Adapter.

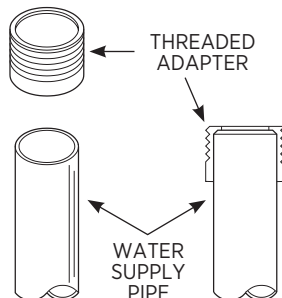

- B** Sweat solder the Adapter to pipe.

- C** Install the Sloan Bak-Chek® Control Stop to the water supply line with the outlet positioned as required. Note: For standard and hydraulic push button applications, concealed valves can be installed with the Control Stop on either the left or right side of the valve.

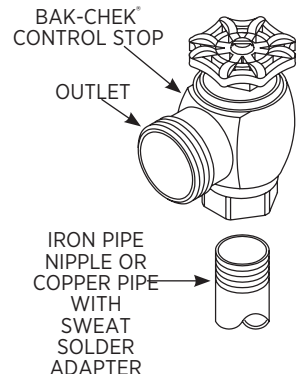

- D** Install Push Button Actuator by following Step 2, 3 or 4 depending on your application.

## 2 - REMOVE PUSH BUTTON ACTUATOR – RETROFIT PUSH BUTTON APPLICATION ONLY

### A TO REMOVE ACTUATOR FROM BEHIND THE WALL:

Remove the Flange and insert Actuator Shaft and Bushing Assembly from the back of the wall through the Combination Fixture or 1-1/2" (38 mm) wall opening.

B Apply several drops of thread sealant to threads of Actuator Shaft at location shown.

C Reinstall and tighten the Flange. Tighten the Mounting Nut against the back of the wall.

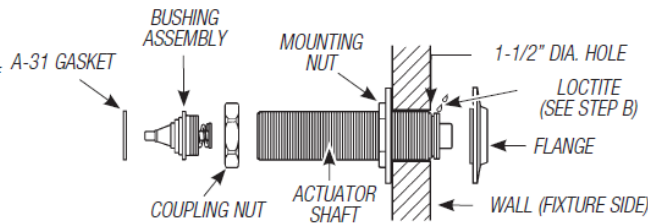

### TO MOUNT ACTUATOR FROM FIXTURE SIDE:

A Remove the Bushing Assembly, Coupling Nut and Mounting Nut from the Actuator Shaft. Insert the Actuator Shaft through the opening in front of the wall.

B Remove Flange from Actuator Shaft. Apply several drops of Loctite to threads of Actuator Shaft at location shown. Reinstall and tighten the Flange.

C Reinstall Mounting Nut onto the Actuator Shaft. Tighten securely until it is against the back of the wall. Reinstall the Coupling Nut, Bushing Assembly and A-31 Gasket.

## 3 - INSTALL PUSH BUTTON ACTUATOR – LED and NON-LED PUSH BUTTON APPLICATION ONLY

### FIXTURE WALL VARIATION METAL PUSH BUTTON ACTUATOR

- A If not already completed, bore a 1-1/2" (38 mm) diameter hole in wall for the Push Button Actuator. Refer to the Rough-in drawings on Pages 2.
- B Screw Threaded Rod into back of Actuator.
- C Thread actuator assembly nut onto threaded end of push button actuator.
- D Apply several drops of Loctite to threads on back side of wall flange to help prevent unscrewing from front of wall.
- E Place Spacer Ring over threads of Button Flange and thread Button Flange Assembly into Actuator Assembly Nut.
- F Insert pushbutton through front of wall and fasten actuator assembly nut.
- G Insert Push Button Actuator Assembly into the 1-1/2" wall hole.

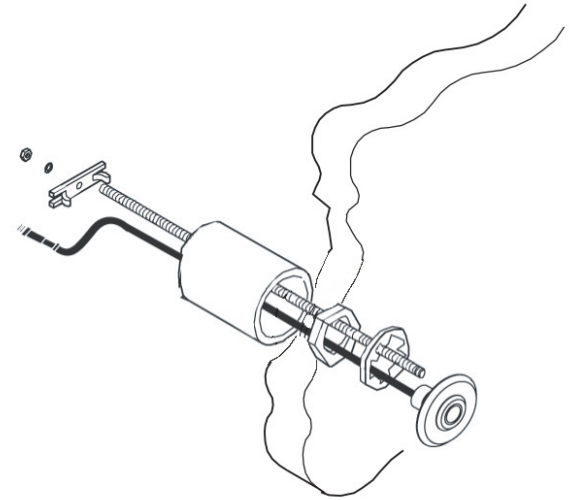

## 4 - INSTALL PUSH BUTTON ACTUATOR – LED and NON-LED PUSH BUTTON APPLICATION ONLY

### PANEL MOUNT VARIATION

- A Thread Actuator Assembly Nut onto threaded end of Push Button Actuator.
- B From front of panel, insert Button Flange Assembly into hole of panel. Behind panel, place Washer over threads of Button Flange. Thread Button Flange onto Actuator. Tighten Flange securely.

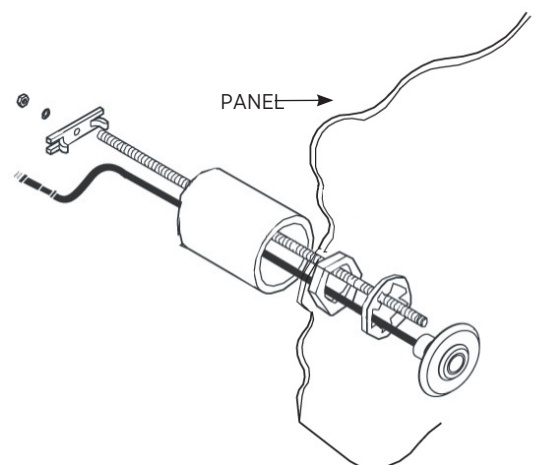

## 5 - INSTALL VACUUM BREAKER AND FLUSH CONNECTION

### !!! IMPORTANT !!!

**DUE TO THE HIGH BACK PRESSURES THAT CAN BE CREATED BY STAINLESS WATER CLOSETS AND COMBINATION FIXTURES, THE FOLLOWING PROCEDURES MUST BE FOLLOWED WHEN INSTALLING THE FLUSH CONNECTION. FAILURE TO FOLLOW THESE PROCEDURES CAN RESULT IN SEPARATIONS. FOR SECURE CONNECTIONS IN HIGHER PRESSURE AND OTHER SEVERE CONDITION APPLICATIONS, THE FLUSH CONNECTIONS CAN BE SWEAT SOLDERED. REMOVE ALL PLASTIC AND RUBBER GASKETS BEFORE BEGINNING SOLDERING PROCESS.**

### NOTE

Sloan Flushmeters are designed to connect to a stainless steel prison fixture in the chase behind the wall. A 1-1/2" (38 mm) pipe connection (NOT supplied by Sloan) must be used to connect the fixture inlet from the wall to the flush connection.

- A** Secure flanged end of F-100 Flush Connection to the 1-1/2" (38 mm) pipe using a 1-1/2" F-2-A Coupling Nut with S-21 Gasket. Tighten securely.

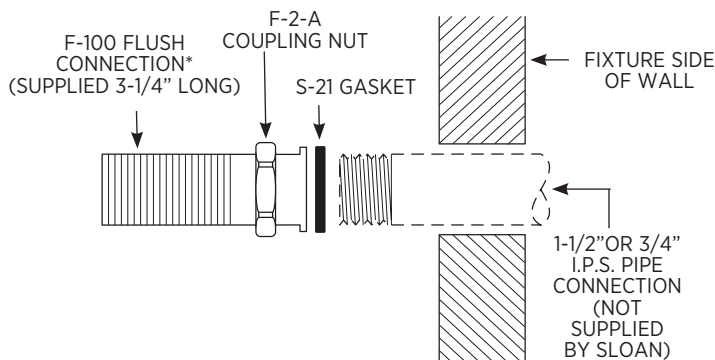

- B** Cut Vacuum Breaker and Flush Connection tubes to length.

### !!! IMPORTANT !!!

**IMPORTANT: WHEN CUTTING SCORED TUBES TO FIT, ALWAYS KEEP AT LEAST 1-1/4" (32 MM) OF SCORING TO ASSURE PROPER ENGAGEMENT WITH COMPRESSION COUPLING.**

- C** Slide the Coupling Nut, Nylon Slip Gasket and Rubber Gasket onto the Vacuum Breaker and Flush Connection tubes.

### Install Slip Elbow

Connect scored ends of vacuum breaker tube and F-100/F-102 flush connection to the elbow using coupling, slip gasket and rubber compression gasket. After applying Loctite® to scored ends, tighten securely.

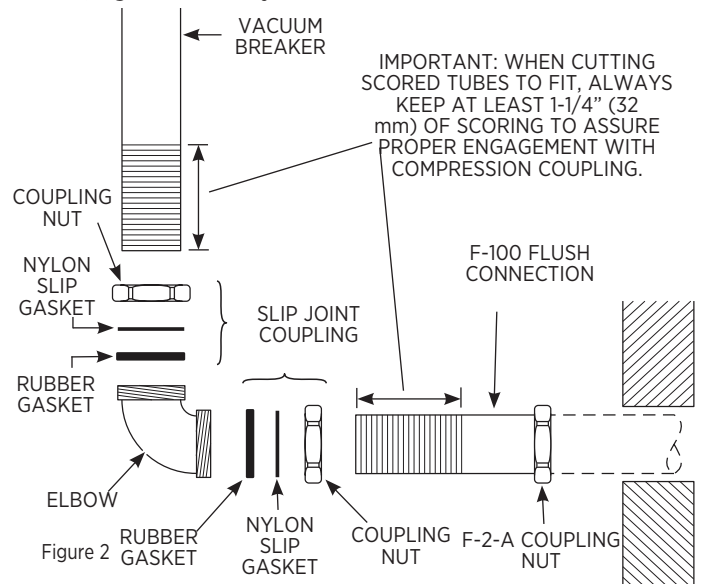

**IMPORTANT:** Before inserting the scored ends into the Elbow, apply several drops of Loctite (supplied by Sloan) to the scored ends of the tubes (Figure 3). This sealant helps prevent separation under high-pressure conditions. **DO NOT** use any other pipe sealant or lubricant on this connection.

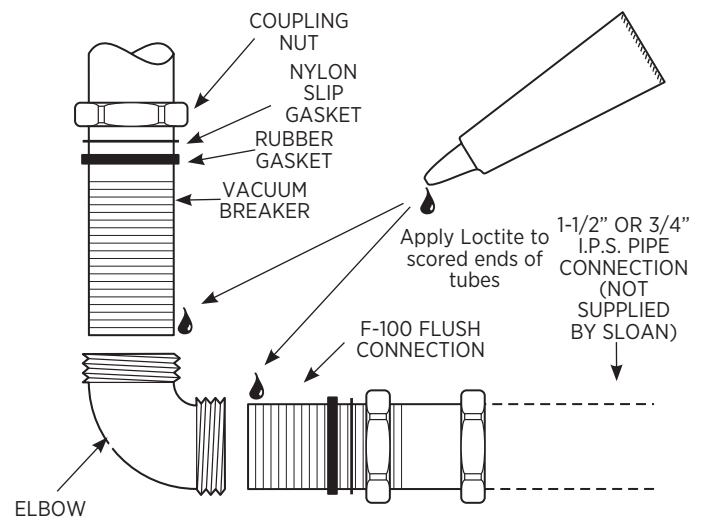
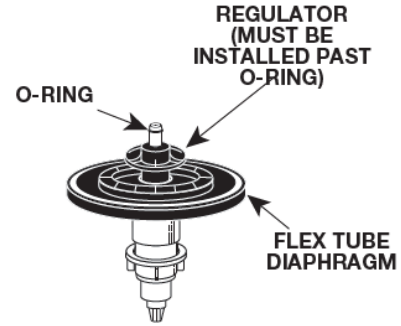

Figure 3 Loctite can also be used to secure Push Button Flange. See Sealant package for details.

**WHEN RETROFITTING AN EXISTING VALVE, START HERE. REMOVE COMPONENTS FROM EXISTING FLUSHOMETER (8603 RESS RETROFIT INSTALLATIONS ONLY)**

The Flush Volume of the 8603 RESS is controlled by the Regulator in the Flex Tube Diaphragm Kit. Regulators are identified by color.

**!!! IMPORTANT !!!**  
**LAWS AND REGULATIONS PROHIBIT THE USE OF HIGHER FLUSHING VOLUMES THAN LISTED ON FIXTURES OR FLUSHOMETERS.**



**6 - ASSEMBLE FLEX TUBE DIAPHRAGM TO 8603 RESS ASSEMBLY**

**A** Make sure Flush Volume Regulator is Installed Past O-ring.

**B** Insert metal end into hole in base of 8603 RESS Assembly. O-ring must be fully inserted into the hole.

**C** Push Diaphragm securely against underside of 8603 RESS Assembly. Place entire Assembly onto the Valve Body.

**NOTE**  
 Sensor Lens must face the chase opening or be aligned to view the window for programming & maintenance.

To facilitate installation, wet the diaphragm assembly (on top or completely).

**7- TIGHTEN LOCKING RING**

- A** Thread Locking Ring onto Valve Body.
- B** Use Strap Wrench provided to tightly secure Locking Ring.



**!!! IMPORTANT !!!**  
 The Locking Ring must be installed down past the valve body threads by at least one thread. If difficulty is experienced installing the Locking Ring, turn the Locking Ring back and forth, each time working it further down the threads. The Locking Ring will act as a thread chaser in the event there has been a build-up of matter on the threads of the old valve body.

If retrofitting the 8603 RESS onto another vendors valve body, a special Locking Ring must be used (identified by a machined groove around the ring).

Order the 8603 RESS with the "Z" ring to receive the unit supplied with this ring.



## 8B- INSTALL FLUSHOMETER

- A** Insert adjustable tailpiece into control stop. (For standard push button, also mount flushometer to actuator assembly.) Lubricate tailpiece o-ring with water. Hand tighten tailpiece coupling. (For standard push button, also hand tighten actuator assembly coupling.)
- B** Align Flushometer directly above the Vacuum Breaker Flush Connection by sliding the Flushometer Body IN or OUT as needed. Tighten Vacuum Breaker Coupling by hand.
- C** Align flushometer body. Using a wrench, securely tighten couplings in the order given: (1) tailpiece coupling, (2) actuator coupling, (3) vacuum breaker coupling, (4) slip joint couplings, and (5) spud coupling.

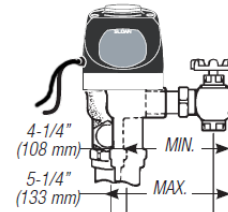

Maximum adjustment of Sloan Adjustable Tailpiece is 1/2" (13 mm) IN or OUT from the standard 4-3/4" (121 mm) (Flushometer centerline to Control Stop centerline). If roughing-in measurement exceeds 5-1/4" (133 mm), consult factory for longer tailpiece.

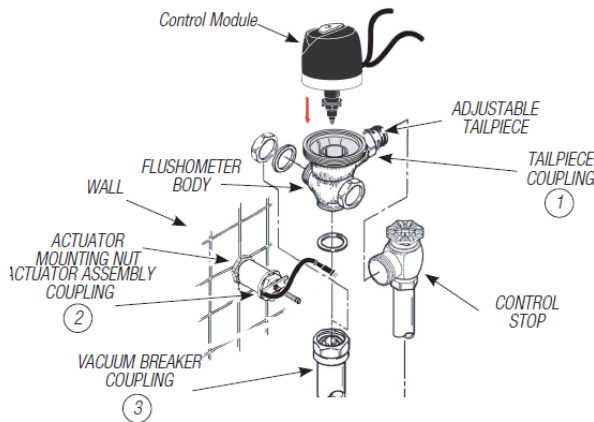

This unit can use 4 (AA) batteries alone, or accept 6 VDC power to function as a hardwired unit with battery backup.

If a 6 VDC plug-in transformer is used, plug it into the appropriate connector to convert the flushometer into a "plug-in with battery back-up".

## 8B- INSTALL EAF-11 TRANSFORMER

Plug the power cable into an EAF-11 Plug in transformer, 6VDC. Then plug the transformer into an electrical outlet. The outlet must be within 24" of the flushometer. If a longer length is needed an extension may be used. A list of extension cables that may be used with the EAF-11 are below.

### EAF Series Extension Cables

- \_ EAF-24-A 11-13/16" (300 mm) Extension Cable
- \_ EAF-25-A 47-1/4" (1200 mm) Extension Cable
- \_ EAF-17-A 126" (3200 mm) Extension Cable

If there is a power failure the batteries in the head assembly will provide power to the flushometer.



## 9 - FLUSH OUT SUPPLY LINE AND ADJUST CONTROL STOP

- A** Shut off Control Stop by turning handle CLOCKWISE. Then remove Flushometer Cover.

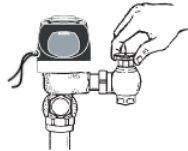

- B** Lift out the inside Parts Assembly as a complete unit. Reinstall Flushometer Cover and tighten with wrench. Open Control Stop. Turn on water supply to flush line of any debris or sediment.

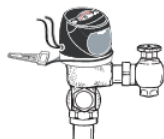

- C** Shut off Control Stop and remove Flushometer Cover. Reinstall Inside Parts Assembly and Flushometer Cover. Tighten Cover with wrench. Open Control Stop and activate Flushometer Valve.



- D** Adjust Control Stop to meet flow rate required for proper cleansing of fixture. Open Control Stop COUNTERCLOCKWISE ONE FULL turn from closed position. Activate Flushometer. Adjust Control Stop after each flush until the rate of flow delivered properly cleanses the fixture.

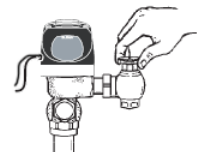

### !!! IMPORTANT !!!

SLOAN PRISON MODEL FLUSHOMETERS ARE ENGINEERED FOR QUIET OPERATION. EXCESSIVE WATER FLOW CREATES NOISE, WHILE TOO LITTLE WATER FLOW MAY NOT SATISFY THE NEEDS OF THE FIXTURE. PROPER ADJUSTMENT IS MADE WHEN THE PLUMBING FIXTURE IS CLEANSED AFTER EACH FLUSH WITHOUT SPLASHING WATER OUT FROM THE LIP AND A QUIET FLUSHING CYCLE IS ACHIEVED.

NEVER OPEN CONTROL STOP TO WHERE THE FLOW FROM THE VALVE EXCEEDS THE FLOW CAPABILITY OF THE FIXTURE. IN THE EVENT OF A VALVE FAILURE, THE FIXTURE MUST BE ABLE TO ACCOMMODATE A CONTINUOUS FLOW FROM THE VALVE.

## TROUBLESHOOTING AND MAINTAINING THE 8603 ESM

**IMPORTANT:** This product contains mechanical and/or electrical components that are subject to normal wear. These components should be checked on a regular basis and replaced as needed to maintain the valve's performance.

Never open Control Stop to where the flow from the valve exceeds the flow capability of the fixture. In the event of a valve failure, the fixture must be able to accommodate a continuous flow from the valve.

**ATTENTION INSTALLERS:** With the exception of the control stop inlet, DO NOT USE pipe sealant or plumbing grease on any valve component or coupling! To protect the chrome or special finish of Sloan flushometers, DO NOT USE toothed tools to install or service these valves. Use our A-50 Super-Wrench™ or other smooth-jawed wrench to secure couplings. Regulations for low consumption fixtures (1.6 gpf/6.0 Lpf closets and 1.0 gpf/3.8 Lpf urinals) prohibit use of higher flush volumes.

### 1. Valve does not flush.

- Check Pushbutton Connection.
- Is the LED on the pushbutton Red? Unit is in Lock-out.
- Does Override flush the unit? If yes, Unit is reset.
- Low Battery indicator (2 quick flashes every 4 seconds).
- Battery needs replacement (4 quick flashes every 4 seconds) unit will not flush.
- If Hardwired, power adapter should be checked to make sure it is properly plugged in.

### 2. Valve does not flush but makes clicking sound.

- No water is being supplied to the valve. Make certain that water supply is turned on and control is open.
- Problem with solenoid. Replace solenoid.

### 3. Valve does not shut off.

- Bypass Orifice in Diaphragm is clogged with dirt or debris, or Bypass is clogged by an invisible gelatinous film due to "over-treated" water. Remove Flex Tube Diaphragm and wash under running water.

**Note:** Size of orifice in the by-pass is of utmost importance for the proper metering of water by the valve. **DO NOT ENLARGE OR DAMAGE THIS ORIFICE.** Replace flex tube diaphragm if cleaning does not correct the problem.

- Dirt or debris fouling Stem or Flex Tube Diaphragm. Remove Flex Tube Diaphragm and wash under running water.
- O-ring on Stem of Flex Tube Diaphragm is damaged or worn. Replace O-ring if necessary.
- Problem with Electronic Sensor Module; replace Sensor Module.

### 4. Not enough water to fixture.

- Wrong Flush Volume Regulator installed in Flex Tube Diaphragm Kit. Install the correct Regulator (see Step 6 of these instructions).
- Wrong Optima Plus' Diaphragm kit installed; i.e., 1 gpf. urinal installed on 3.5 gal. closet fixture. Replace with proper Optima Plus diaphragm kit.
- Enlarged Bypass in Diaphragm. Replace Flex Tube Diaphragm.
- Control Stop not adjusted properly. Readjust Control Stop.
- Inadequate volume or pressure at supply. Increase water

pressure or supply (flow) to valve. Consult factory for assistance.

- Head not securely tightened on flushometer body. Tighten using strap wrench.

### 5. Too much water to fixture.

- Wrong Flush Volume Regulator installed in Flex Tube Diaphragm Kit. Install the correct Regulator (see Step 6 of these instructions).
- Control Stop not adjusted properly. Readjust Control Stop.
- Wrong Optima Plus Diaphragm kit installed; i.e., 3.5 gpf. closet installed on 0.5 gal. urinal fixture. Replace with proper Optima Plus Diaphragm kit.
- Dirt in Diaphragm Bypass. Clean under running water or replace Flex Tube Diaphragm.

### SETTING THE PROGRAM

- Press and hold override Button. Continue holding the button until the desired program is reached.
- After about 5 seconds, the LED will turn on for 3 seconds indicating the start of the program section period.
- LED will blink in 2 second intervals indicating the program.
- Count the blinks until the desired program number, then release the button. For example, if you want program #3, release the button after the LED blinks for the third time.
- After the button is released, the LED display will blink indicating which program is selected.
- Unit comes with program #1 as default program.

### PROGRAM

- Release button after 1st blink: 2 activations in a 5 minute window with a lockout of 15 minutes (default program).
- Release button after second blink: 2 activations in a 5 minute window with a lockout of 30 minutes.
- Release button after 3rd blink: 2 activations in a 5 minute window with a lockout of 45 minutes.
- Release button after 4th blink: 2 activations in a 5 minute window with a lockout of 60 minutes.
- Release button after 5th blink: 1 activation with a backside delay of 60 seconds/no lockout.
- Check which program is running. Press and release override button, flush should happen right away, then LED will blink the number of corresponding program number.

### CARE OF CHROME AND SPECIAL FINISHES

**DO NOT USE** abrasive or chemical cleaners to clean flushometers as they may dull the luster and attack the chrome or special decorative finishes.

Use **ONLY** soap and water, then wipe dry with clean cloth or towel.

While cleaning the bathroom tile, the flushometer should be protected from any splattering of cleaner. Acids and cleaning fluids can discolor or remove chrome plating.

**When assistance is required, please contact**

**Sloan Technical Support at: 1-888-SLOAN-14 (1-888-756-2614).**

## CARE AND CLEANING

DO NOT use abrasive or chemical cleaners (including chlorine bleach) to clean Flushometers that may dull the luster and attack the chrome or special decorative finishes. Use ONLY mild soap and water, then wipe dry with clean cloth or towel.

While cleaning the bathroom tile, protect the Flushometer from any splattering of cleaner. Acids and cleaning fluids will discolor or remove chrome plating.

## PARTS LIST

Item No.	Part No.	Description
1.	†	Valve Body
2.	H-730-A RB	Wheel Handle Bak-Chek® Control Stop
3.	†	Push Button Actuator Assembly
4.	A-1013-A	RB Concealed Handle Cap Kit
5.	V-500-AA	1 ½" (38 mm) x 10-1/2" (267 mm) Vacuum Breaker Assembly RB
6.	F-2-AA	1-1/2" (38 mm) Slip Joint Couplings (two per package)
7.	F-21 RB	1-1/2" (38 mm) EL Double Male Slip Joint
8.	F-100	1-1/2" (38 mm) x 3-1/4" Flared End Flush Connection
9.	F-2-A	1-1/2" (38 mm) Coupling with S-21 Gasket
10.	EAF-11	Adapter 6.75 VDC Plug-in (US)

### EAF Series Extension Cables

11.	EAF24A	11-13/16" (300mm) Extension Cable
	EAF25A	47 1/4" (1200mm) Extension Cable
	EAF17A	126" (3200mm) Extension Cable

Not Shown Loctite Thread Sealant

† Part number varies with valve model variation; consult factory.

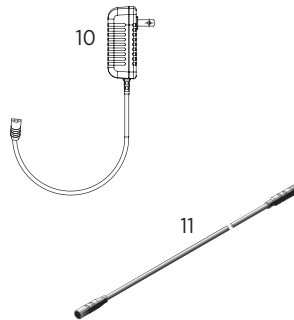

**When assistance is required, please contact your local Sloan Representative or Sloan Technical Support at: +1.888.SLOAN.14 (+1.888.756.2614)**

Manufactured in the U.S.A. by Sloan Valve Company under one or more of the following patents: U.S. Pats. 5,295,655; 5,542,718; 5,558,120; 5,564,460; 5,865,420; 5,887,848; 5,967,182. Other Pats. Pending. BAK-CHEK, PARA-FLO, PERMEX, TURBO-FLO.

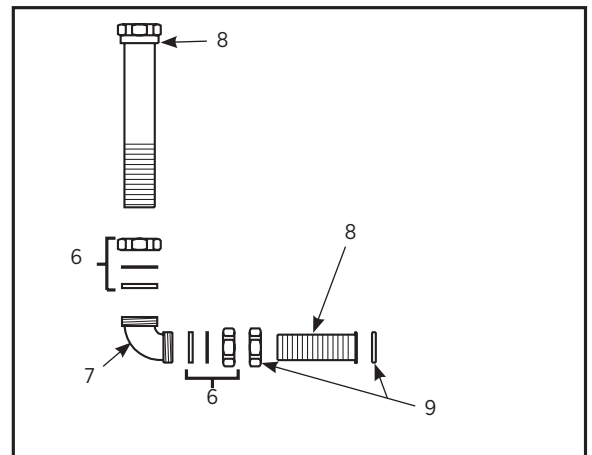
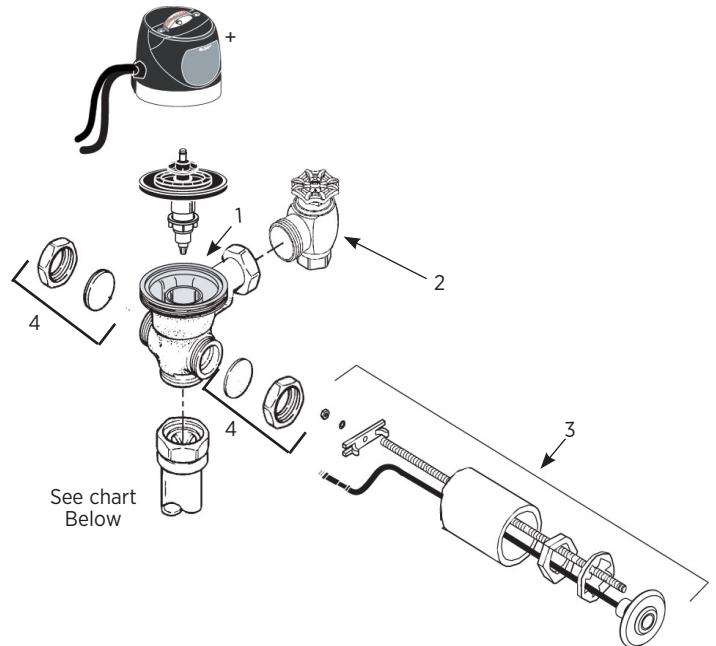

MODEL 8603 ESM

NOTE: The information contained in this document is subject to change without notice.

**SLOAN • 10500 SEYMOUR AVENUE • FRANKLIN PARK, IL 60131**  
Ph: +1.800.9.VALVE.9 or +1.800.982.5839 • Fax: +1.800.447.8329 • sloan.com