

INSTALLATION INSTRUCTIONS FOR OPTIMA® SYSTEMS SENSOR ACTIVATED SLIMLINE BEDPAN WASHER WITH EXPOSED ROYAL® SLOAN® AND REGAL® FLUSHOMETER

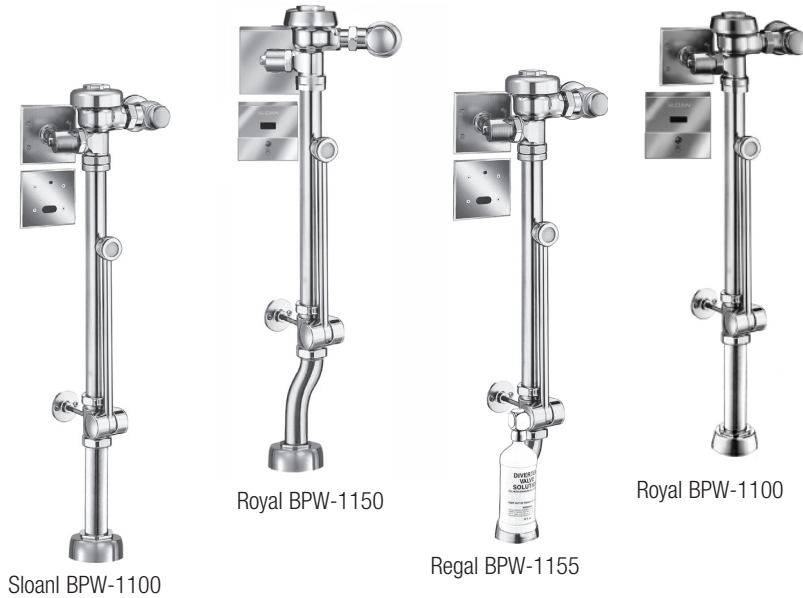

- Slimline® Bedpan Washers
- BPW-1000 Standard
- Slimline® Bedpan Washers for ADA Installations
- BPW-1100 Standard
- BPW-1150 With Grab Bar Offset
- BPW-1155 With Grab Bar Offset & Deoseptic Unit
- Slimline® Bedpan Washers — Diverter Assemblies
- DV-100 Standard
- DV-105 With Deoseptic Unit
- DV-110 For ADA Installation
- DV-115 For ADA Installation With Deoseptic Unit
- DV-120 With Grab Bar Offset
- DV-125 With Grab Bar Offset & Deoseptic Unit
- DV-130 Replacement Model
- DV-135 Replacement Model With Deoseptic Unit

LIMITED WARRANTY

Sloan Valve Company warrants its ES-S Sensor Activated Sloan® and Regal® Bedpan Washer to be made of first class materials, free from defects of material or workmanship under normal use and to perform the service for which they are intended in a thoroughly reliable and efficient manner when properly installed and serviced, for a period of three years (1 year for special finishes) from date of purchase. During this period, Sloan Valve Company will, at its option, repair or replace any part or parts which prove to be thus defective if returned to Sloan Valve Company, at customer's cost, and this shall be the sole remedy available under this warranty. No claims will be allowed for labor, transportation or other incidental costs. This warranty extends only to persons or organizations who purchase Sloan Valve Company's products directly from Sloan Valve Company for purpose of resale.

THERE ARE NO WARRANTIES WHICH EXTEND BEYOND THE DESCRIPTION ON THE FACE HEREOF. IN NO EVENT IS SLOAN VALVE COMPANY RESPONSIBLE FOR ANY CONSEQUENTIAL DAMAGES OF ANY MEASURE WHATSOEVER.

VALVE ROUGH-IN

BPW-1000 ESS

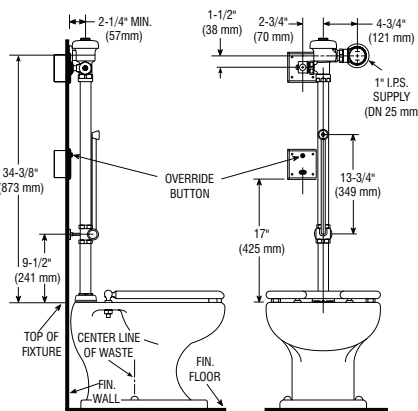

BPW-1100 ESS

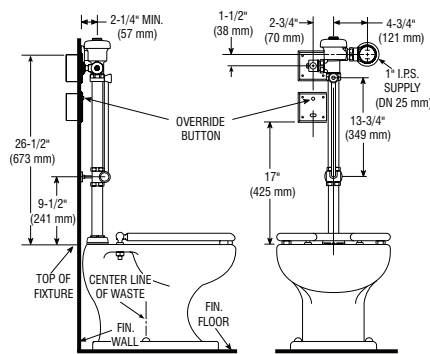

BPW-1150 ESS

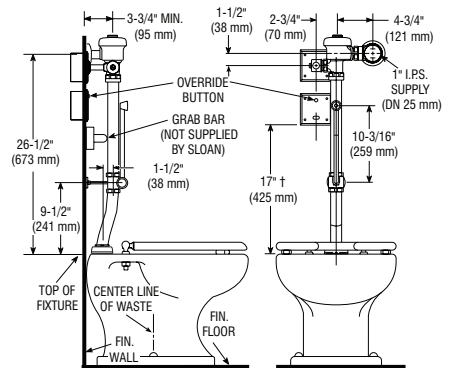

BPW-1155 ESS

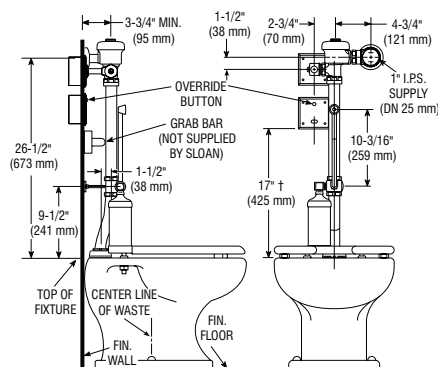

FLUSH VOLUME

BPW VALVE CAN BE PROVIDED WITH THE FOLLOWING FLUSHING VOLUMES:

- Standard — Water Saver, 3.5 gpf (13.2 Lpf)
- "-1.6" — Low Consumption, 1.6 gpf (6.0 Lpf)
- "-2.4" — 2.4 gpf (9.0 Lpf)
- "-1.28" — High Efficiency 1.28 gpf (4.8 Lpf)

‡ POSITION OF SENSOR BOX CAN BE RAISED OR LOWERED 1" (25 mm) IF IN CONFLICT WITH HANDICAP GRAB BARS.

SENSOR LOCATION & POSITIONING IS CRITICAL!

Failure to properly position the electrical boxes to the plumbing rough-in will result in improper installation and impair product performance. All tradesmen (plumbers, electricians, tile setters, etc.) involved with the installation of this product must coordinate their work to assure proper product installation.

PRIOR TO FLUSHOMETER INSTALLATION

Before you install the Sloan OPTIMA equipped Flushometer, install the items listed below. Refer to Rough-ins on Page 1 and illustrations on this page.

- 2-gang electrical box — 4" x 4" x 2-1/2" (102 mm x 102 mm x 64 mm) for sensor; see paragraph entitled "Sensor/Solenoid Operator Box Locations"
- 2-gang electrical box — 4" x 4" x 2-1/2" (102 mm x 102 mm x 64 mm) for transformer; see paragraph entitled "Transformer Installation" (mount in a convenient location)
- 2-gang electrical box — 4" x 4" x 2-1/2" (102 mm x 102 mm x 64 mm) for solenoid operator, see paragraph entitled "Sensor/Solenoid Operator Box Locations"
- Electrical wiring to the transformer box (120 VAC, 2 amp service required for each EL-154, 24 VAC, 50 VA transformer used)
- Closet fixture
- Drain line
- Water supply line

Important:

- INSTALL ALL ELECTRICAL WIRING IN ACCORDANCE WITH NATIONAL/LOCAL CODES AND REGULATIONS.
- INSTALL ALL PLUMBING IN ACCORDANCE WITH APPLICABLE CODES AND REGULATIONS.
- WATER SUPPLY LINES MUST BE SIZED TO PROVIDE AN ADEQUATE VOLUME OF WATER FOR EACH FIXTURE.
- A 24 VAC STEP-DOWN TRANSFORMER MUST BE USED.
- USE APPROPRIATE PRECAUTIONS WHILE CONNECTING TRANSFORMER TO 120 VAC POWER SOURCE.
- FLUSH ALL WATER LINES PRIOR TO MAKING CONNECTIONS.

Sloan® and Regal® Flushometers are designed to operate with 15 to 100 psi (104 to 689 kPa) of water pressure. THE MINIMUM PRESSURE REQUIRED TO THE VALVE IS DETERMINED BY THE TYPE OF FIXTURE SELECTED. Consult fixture manufacturer for minimum pressure requirements.

Most Low Consumption water closets (1.6 gallon/6.0 liter) require a minimum flowing pressure of 25 psi (172 kPa).

Transformer Installation

Install Transformer (EL-154) on a 2-Gang Electrical Box, 4" x 4" x 2-1/2" (102 mm x 102 mm x 64 mm) in a convenient location; refer to the illustration at upper right side of this page.

Note: One Sloan EL-154 transformer can operate up to ten OPTIMA equipped Flushometers. Run 18-gauge wire from transformer to Flushometer(s). Wire supplied by others. **DO NOT supply power to transformer until installation of Flushometer is complete.**

Note: A maximum of ten (10) Flushometer units can operate from one (1) Sloan EL-154 Transformer, Class 2, UL Listed, 50 VA (min.) at 24 VAC, plate mounted.

Sensor/Solenoid Operator Box Locations

Exposed closet models employ two (2) electrical boxes. Refer to rough-in illustrations for locations.

ELECTRICAL BOX LOCATION IS CRITICAL — Failure to properly position the electrical boxes to the plumbing rough-in will result in improper installation and impair product performance. All

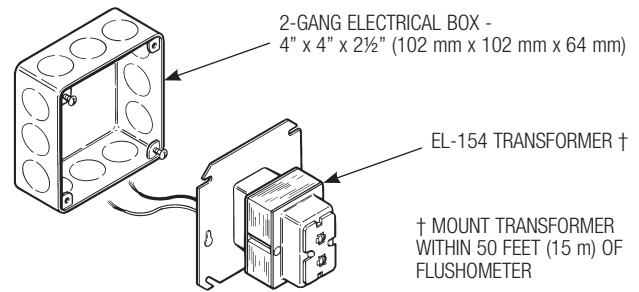

tradesmen (plumbers, electricians, tile setters, etc.) involved with the installation of this sensor activated flushometer must be familiar with the requirements of its installation. Improper installation may void the manufacturer's warranty.

Note: Use Appleton #4SD1 Electrical Box and #8470 Plaster Ring or equivalent.

Note: Install plaster ring so screw holes are on left and right side of box.

Note: Break tiles to allow screw holes in plaster to show.

Tools Required for Installation

- Slotted screwdriver
- 5/64" hex wrench (supplied)
- Wire stripper/crimping tool
- Sloan A-50 Super-Wrench™, Sloan A-109 Plier Wrench or smooth jawed spud wrench

!!! IMPORTANT !!!

With the exception of Control Stop Inlet, DO NOT use pipe sealant or plumbing grease on any valve component or coupling!

Never open Control Stop to where the flow from the valve exceeds the flow capability of the fixture. In the event of a valve failure, the fixture must be able to accommodate a continuous flow from the valve.

Protect the chrome or special finish of Sloan Flushometers — DO NOT USE toothed tools to install or service these valves. Use a Sloan A-50 Super-Wrench™, Sloan A-109 Plier Wrench or smooth jawed spud wrench to secure all couplings. Also see "Care and Cleaning" section of this manual.

This product contains mechanical and/or electrical components that are subject to normal wear. These components should be checked on a regular basis and replaced as needed to maintain the valve's performance.

Please take the time to read this manual to ensure proper product installation and longevity. Also, please visit our website to download our most recent documentation for this product.

If you have questions about how to install your Sloan Flushometer, consult your local Sloan Representative or call Sloan Installation Engineering Department at:

1-888-SLOAN-14 (1-888-756-2614)

ELECTRICAL BOX INSTALLATION DIAGRAM

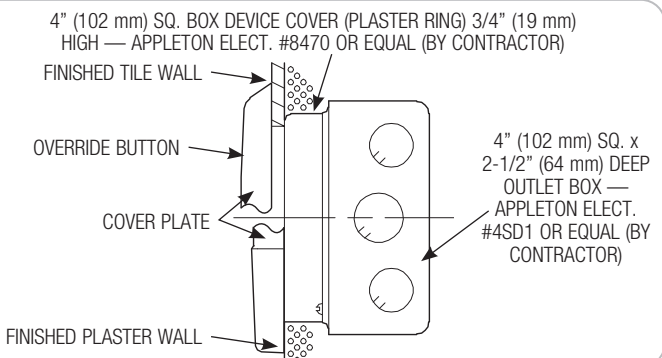
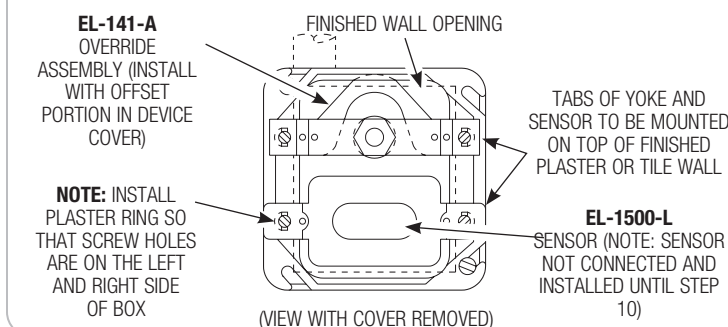

1 Install Optional Sweat Solder Adapter (only if your supply pipe does not have a male thread)

A Measure from finished wall to C/L of Fixture Spud. Cut pipe 1 1/4" (32 mm) shorter than this measurement. Chamfer O.D. and I.D. of water supply pipe.

B Slide Threaded Adapter fully onto pipe.

C Sweat solder the Adapter to pipe.

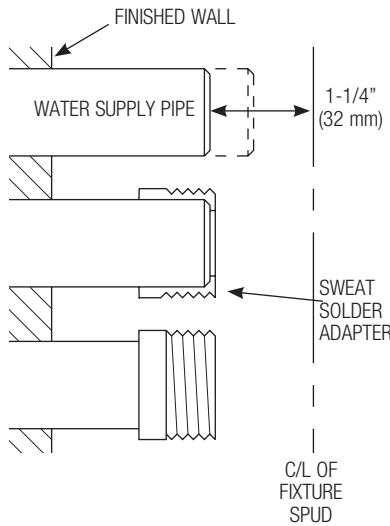

2 Install Cover Tube, Wall Flange and Control Stop to supply pipe

A Measure from finished wall to first thread of Adapter or threaded supply pipe (dimension "X"). Cut Cover Tube to this length.

B Slide Cover Tube over pipe. Slide Wall Flange over Cover Tube until against wall.

C Thread Control Stop onto pipe. Tighten with a wrench.

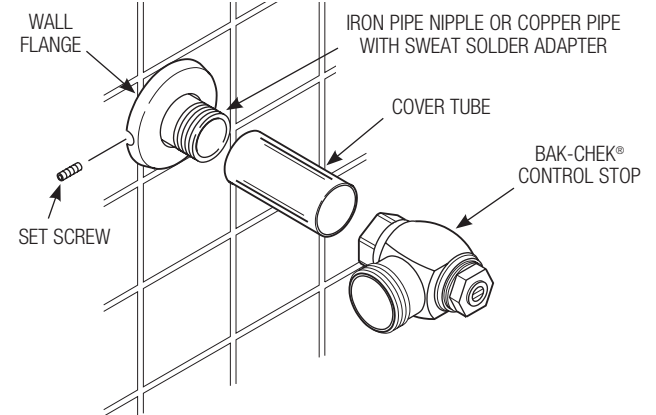

3 Install Flanged Outlet Tube (Retrofit applications start here)

A Slide the Diverter Valve Coupling Nut, Spud Coupling, Nylon Slip Gasket, Rubber Gasket and Spud Flange over the Flanged Outlet Tube and insert tube into fixture spud.

B Hand tighten Spud Coupling onto fixture spud.

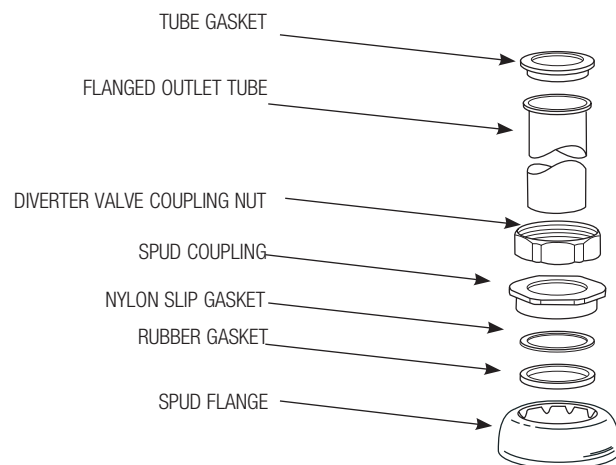

C Place tube gasket on top of flanged outlet tube as shown.

4 Install Diverter Valve and Wall Support Flange

A Position Diverter Valve on top of Tube Gasket and secure with Diverter Valve Coupling Nut. Tighten Diverter Valve Coupling Nut hand tight.

B Determine the required length of Support Rod by measuring distance between finished wall and back of Diverter Valve at Support Rod Hole (Dimension "X"). Add 1/4" (6 mm) to the length determined and cut the Support Rod to size.

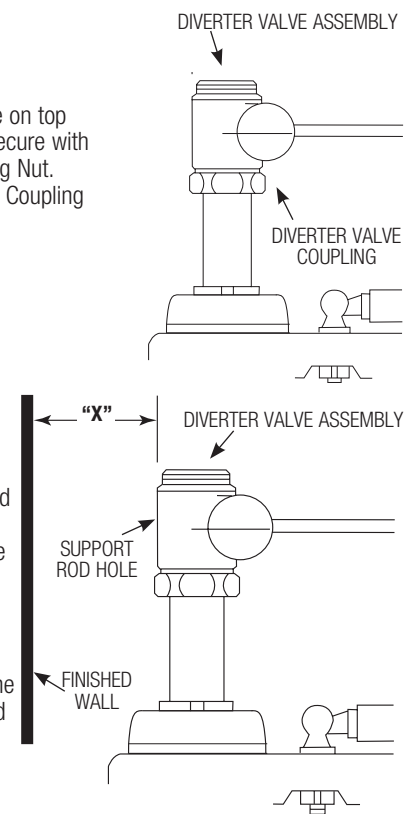

4 Install Diverter Valve and Wall Support Flange (continued)

- C** Turn the Diverter Valve Assembly to allow threading Support Rod into back of Diverter Body. Slide Wall Support Flange onto Support Rod and turn the Diverter Valve Assembly so that Wall Support Flange is flush with wall.
- D** Use Wall Support Flange as a template and mark off holes on finished wall for mounting screws. Remove Diverter Valve Assembly and drill a 5/16" (8 mm) hole at the two locations marked. Install an anchor in each 5/16" (8 mm) hole.
- E** Rotate Diverter Valve so that Support Rod Flange mounting holes are aligned with two mounting holes in finished wall. Secure using the two (2) screws provided. Tighten Set Screw in Wall Support Flange.

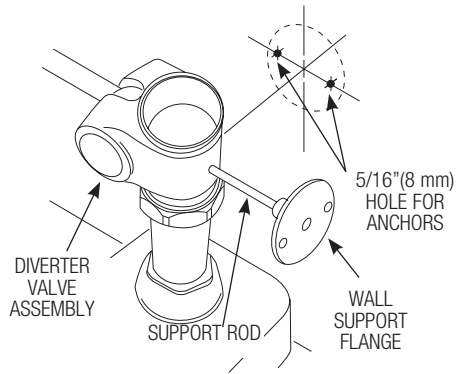

5 Install Deoseptic Unit (Deoseptic Models Only)

- A** Connect Aspirator Tube to Deoseptic Swivel.
- B** Screw Bottle onto Deoseptic Swivel.

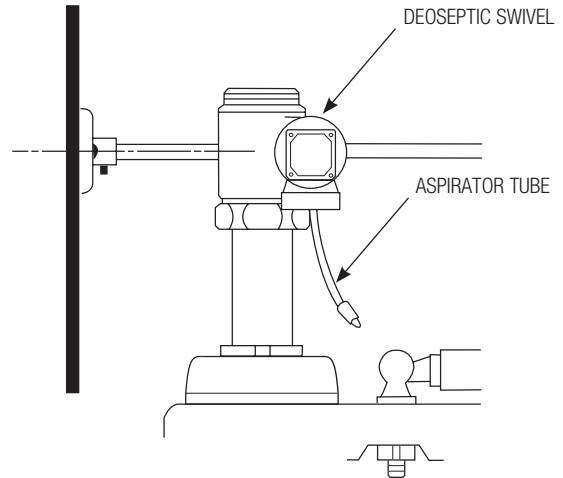

6 Install Vacuum Breaker Flush Connection

- A** Slide the Diverter Valve Coupling Nut, Nylon Slip Gasket and Rubber Gasket over the Vacuum Breaker Tube and secure tube to Diverter Valve Assembly.

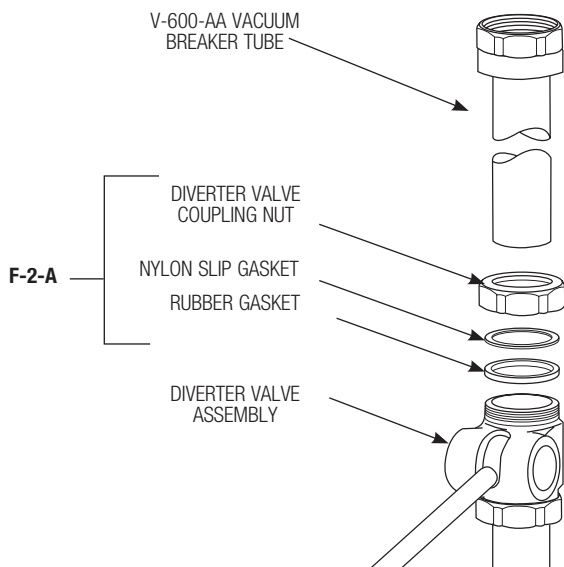

- B** Hand tighten Diverter Valve Coupling Nut onto Diverter Valve Assembly.
- C** Length of Vacuum Breaker Tube may be shortened to accommodate lower valve installation height.

7 Install Flushometer

NOTE

Max. adjustment of Sloan Adjustable Tailpiece is 1/2" (13 mm) IN or OUT from the standard 4 3/4" (121 mm) (c/l of Valve to c/l of Control Stop).

If roughing-in measurement exceeds 5 1/4" (133 mm), consult factory for longer tailpiece.

- A** Lubricate tailpiece O-ring with water. Insert Adjustable Tailpiece into Control Stop. Tighten Tailpiece Coupling by hand.
- B** Align Flushometer directly above the Vacuum Breaker Flush Connection by sliding the Flushometer Body IN or OUT as needed. Tighten Vacuum Breaker Coupling by hand.

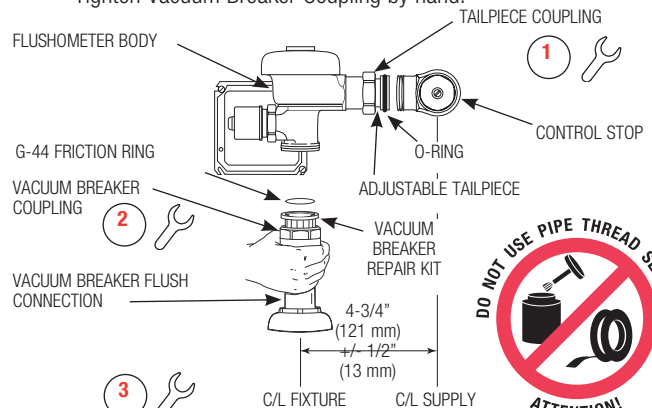

- C** Align Flushometer Body and securely tighten first the Tailpiece Coupling (1), then the Vacuum Breaker and Pipe Couplings (2), and finally the Spud Coupling (3). Use a wrench to tighten these couplings in the order shown.



8 Connect Solenoid Operator

- A** To ease installation, remove the Solenoid Operator from the Flushometer; however, prior to removal, read and adhere to the following precautions.
 - When removing the Coil from the Solenoid Plunger Guide, do so only with the power **OFF**. Failure to turn power off can result in damage to the Sensor, Solenoid Coil and Transformer.
 - When removing the Solenoid Operator from the Valve, take care not to damage the O-ring seal on the Operator Assembly.
- B** Slide Coil wires through Tail (F-15) and screw Tail into Solenoid Housing (EL-162-2).
- C** Slide Flange Assembly (EL-431-A) and Cover Plate (EL-625) over Tail, respectively.

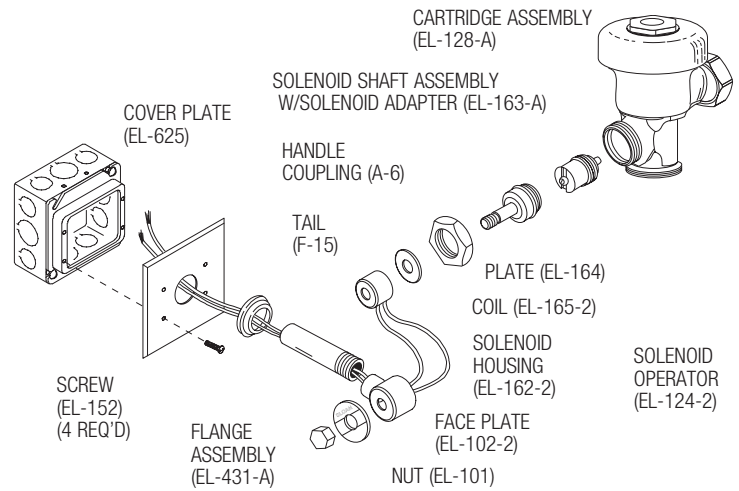

EXPOSED URINAL FLUSHOMETER

EXPOSED CLOSET FLUSHOMETER

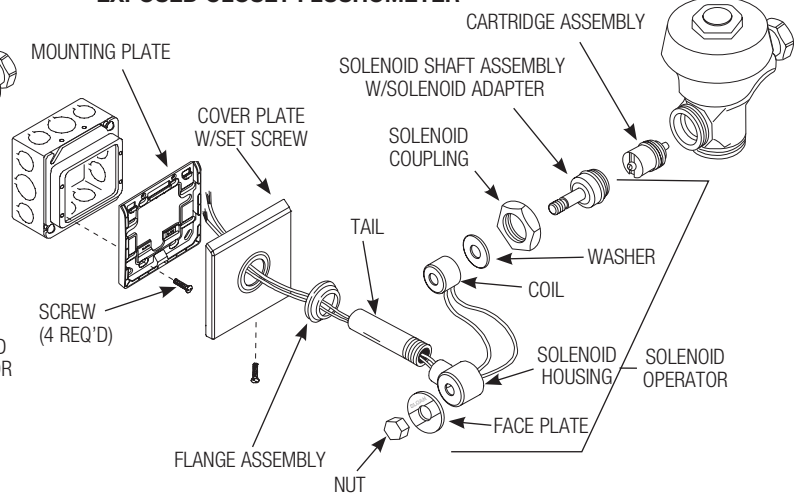
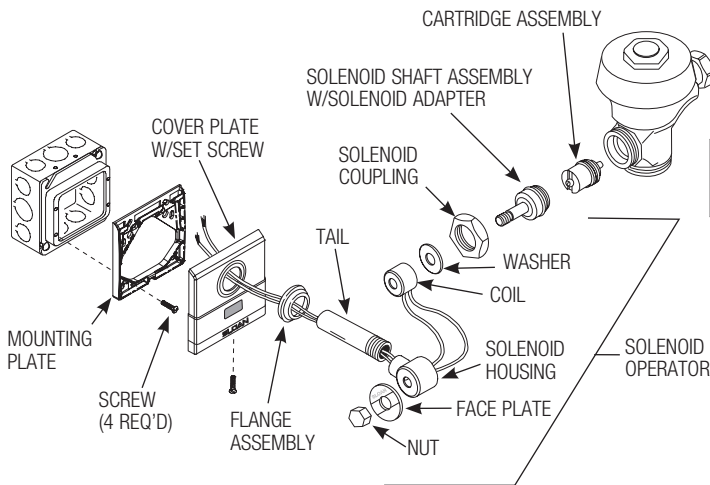

9 Electrical Hook-Up

- A** Be certain power is **OFF** to prevent damage to electrical components. Connect Sensor to Transformer and Solenoid coil EXACTLY as shown.
- B** Connect 24 volt source lead to terminal labeled "24 VAC IN" of Sensor.
- C** Connect solenoid lead to terminal labeled "TO VALVE" of Sensor.
- D** Connect remaining solenoid lead to remaining 24 volt source lead.
- E** Connect Override Button parallel to the EL-1500-L Sensor. Use 18 gauge wire between Override Button terminals and the connection of the EL-1500-L Sensor

Important: Do not remove coil from solenoid plunger guide unless power has been disconnected. Failure to do so may damage sensor, coil and transformer.

Wiring Diagram for One Flushvalve

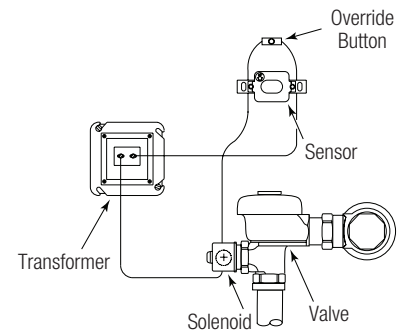

Wiring Diagram for Multiple Flushvalves

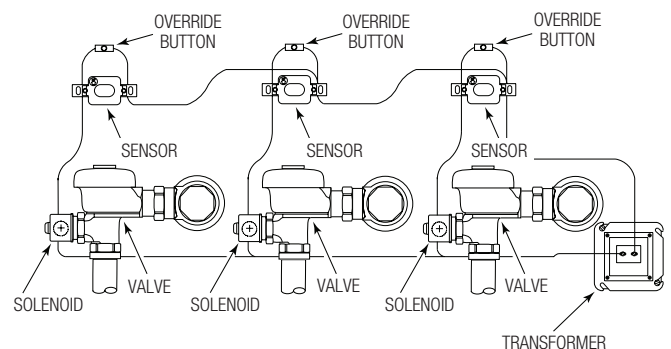

WIRING DIAGRAM

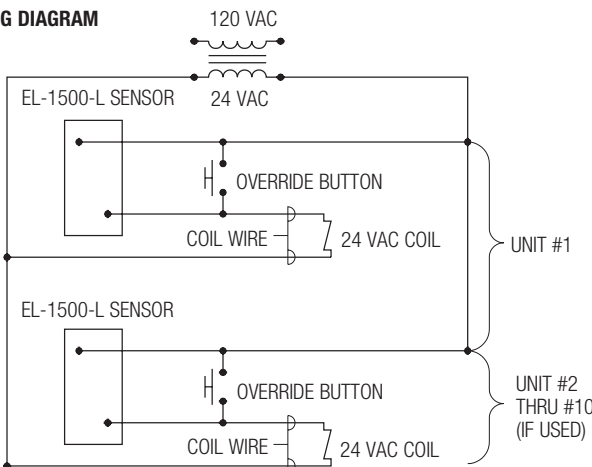

10 Install Sensor, Yoke, Override Button and Cover Plate

- A** Install OPTIMA Sensor (EL-1500-L) into the 2-gang Electrical Box using two (2) long screws provided. Ensure that Sensor Lens faces outward and horizontally from finished wall
- B** Install Inner Nut, Bracket and Outer Nut on threaded shaft of Override Button.
- C** Mount Bracket to Yoke.
- D** Adjust distance that Override Button will protrude through Wall Plate using Nut on each side of Bracket. Threaded shaft end of Override Button should be flush with Wall Plate. Override Button should be connected parallel to the EL-1500-L Sensor.
- E** Mount assembled Yoke to Electrical Box.
- F** Install Sensor Cover Plate (EL-201) and secure with Tamper-Proof Screws (EL-152).

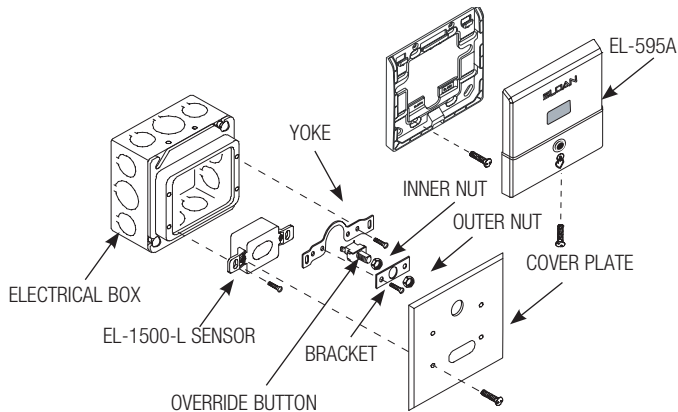

11 Install Solenoid Cover Plate and Secure Solenoid Housing and Coil Assembly

- A** Install Solenoid Operator Cover Plate and secure with the Tamper-Proof Screws provided.
- B** Slide Solenoid Flange Assembly (EL-431-A) against Cover Plate and tighten Setscrew to Tail (F-15).
Note: Hex key wrench services Tamper-Proof Screws and Setscrew. Tighten solenoid Nut (EL-101).
- C** Carefully install Solenoid Operator to Flushometer while aligning Tail to Solenoid Cover Plate. Wet O-Ring seal of Solenoid Operator with water to lubricate. Secure Solenoid Operator to Flushometer by tightening Solenoid Coupling. Slide Solenoid Flange Assembly against Solenoid Cover Plate and tighten Set Screw to Tail.

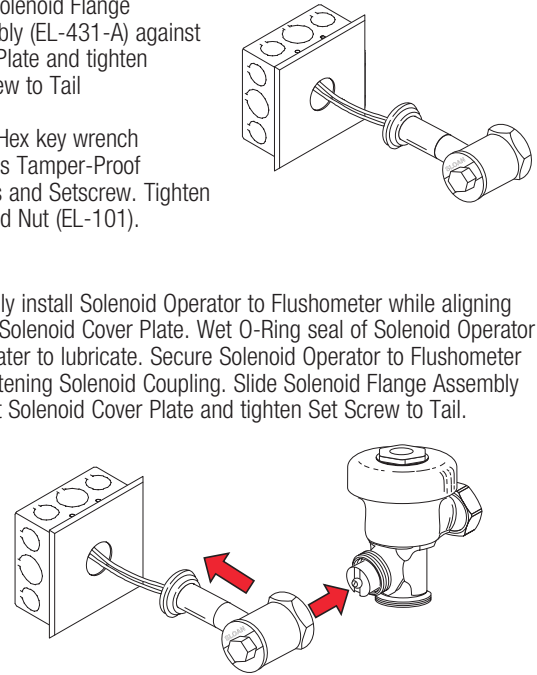

12 Flush Out Supply Line

- A** Make sure Control Stop is CLOSED.
- B** Remove Flushometer Cover and lift out Inside Parts Assembly. Install Flushometer Cover wrench tight.
- C** Open Control Stop. Turn on water supply to flush line of any debris or sediment.
- D** Shut off Control Stop, remove Cover and reinstall Inside Parts Assembly. Install Flushometer Cover wrench tight. Do Not open Control Stop until Step 15.

13 Power and Start-up Mode

- Note:** It is recommended that all electronic connections be tested with the water supply **OFF**.
- A** Turn Power **ON**. The self adaptive sensor automatically adapts to the surrounding environment when 24 volt supply is activated. No manual adjustments are required.
 - B** Start-up mode will take approximately five (5) minutes to complete its cycle and is important that no non-permanent target is present at this time. A continuous red light visible in sensor window indicates sensor is in the start-up mode. If the red light is flashing, this indicates that the sensor is picking up a target. Unless this target is a permanent fixture in the sensor's environment (i.e., a wall or stall door), it must be removed from the view of the sensor. If this target is permanent, the sensor will adapt itself around this target. In this case, the start-up mode may take up to ten (10) minutes. When the start-up cycle is completed, no light is visible in sensor window.
- Note:** If 24 volt power supply is interrupted at any time for more than fifteen (15) seconds, the start-up mode automatically repeats itself when power is restored.
- C** If indicator light flashes three (3) times slowly, three (3) times rapidly and again three (3) times slowly and continually repeats this signal, this indicates incorrect wiring or a short in the 24 volt supply. The EL-1500-L self-adaptive sensor is equipped with the sentinel flush feature (automatically flushes every twenty-four (24) hours after last use).

14 Detection/Activation

- A** When an object is detected, a slowly flashing red light will appear in the sensor window. After approximately eight (8) to ten (10) seconds, the light will flash rapidly indicating sensor is armed and ready to activate solenoid when the object leaves the detection area. The solenoid will be activated within two (2) to four (4) seconds after non-detection.

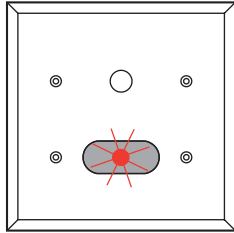

15 Turn Water on and Adjust Control Stop

- A** Adjust Control Stop to meet the flow rate required for proper cleansing of the fixture. Open Control Stop COUNTERCLOCKWISE 1/2 turn from the closed position.

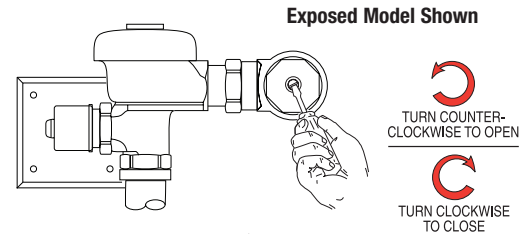

- B** Activate Flushometer by placing hand in front of OPTIMA Sensor Lens for ten (10) seconds and then moving it away.
- C** Adjust Control Stop after each flush until the rate of flow delivered properly cleanses the fixture.

!!! IMPORTANT !!!

The Sloan® and Regal® Flushometer is engineered for quiet operation. Excessive water flow creates noise, while too little water flow may not satisfy the needs of the fixture. Proper adjustment is made when plumbing fixture is cleansed after each flush without splashing water out from the lip AND a quiet flushing cycle is achieved.

Never open Control Stop to where the flow from the valve exceeds the flow capability of the fixture. In the event of a valve failure, the fixture must be able to accommodate a continuous flow from the valve.

16 Adjust Volume of Solution Drawn from Deoseptic Bottle (Models with Deoseptic Unit Only)

- A** Using a screwdriver blade, pry off plug button on side of deoseptic swivel. Turn deoseptic adjustment screw as follows:

Clockwise to DECREASE volume of solution drawn during flush

Counterclockwise to INCREASE volume of solution drawn during flush

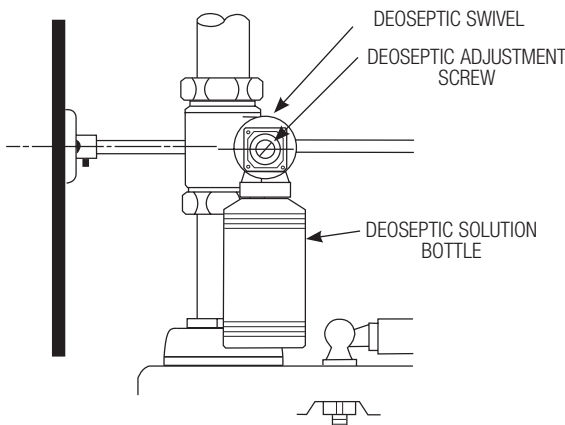

- B** Replace plug button after making adjustment.

Operation

1. A continuous, invisible light beam is emitted from the OPTIMA Sensor.
2. When a user enters the beam's effective range, 22 to 42 inches (559 mm to 1067 mm), the beam is reflected into the OPTIMA's scanning window and transformed into a low voltage electrical signal that activates a ten-second time delay circuit. The time delay circuit eliminates false operation from passers-by in the rest room. Once the time delay is completed, the output circuit is alerted and continues in a "hold" mode for as long as the user remains within the effective range of the sensor.
3. When the user steps away from the OPTIMA Sensor, the loss of reflected light initiates an electrical "one-time" signal that energizes the Solenoid Operator, and activates the Flushometer to flush the fixture. This occurs approximately three (3) seconds after indication. This delay is built into the Sensor to help prevent false flushing due to movement by the user. The circuit then automatically resets and is ready for the next user.

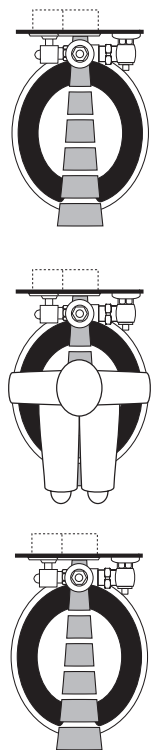

Care and Cleaning

DO NOT use abrasive or chemical cleaners (including chlorine bleach) to clean Flushometers that may dull the luster and attack the chrome or special decorative finishes. Use **ONLY** soap and water, then wipe dry with clean cloth or towel.

While cleaning the bathroom tile, the Flushometer should be protected from any splattering of cleaner. Acids and cleaning fluids can discolor or remove chrome plating.

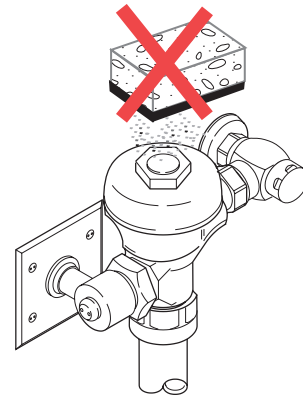

TROUBLESHOOTING GUIDE

NOTE: Upon detection of the user, the red indicator light flashes **slowly** for a period of eight seconds. When the user leaves the detection range, the indicator light flashes **rapidly** and the Sensor initiates the flush sequence. Then the indicator light **stops** flashing and the valve flushes. The valve will flush after a three-second delay.

1. PROBLEM: Valve does not function (red light does not flash when user steps in front of sensor).

CAUSE: No power is being supplied to sensor.

SOLUTION: Ensure that the main power is turned "ON." Check transformer, leads and connections. Repair or replace as necessary.

CAUSE: EL-1500-L Sensor is not operating.

SOLUTION: Replace EL-1500-L Sensor.

2. PROBLEM: Valve does not function (red light flashes when user steps in front of Sensor).

INDICATOR: Red light stops flashing when user steps away and valve makes a "clicking" sound but does not flush.

CAUSE: No water is being supplied to the valve.

SOLUTION: Make certain that water supply is turned "ON" and the Control Stop is open.

CAUSE: EL-128-A cartridge is fouled or jammed.

SOLUTION: Turn electronic power to valve "OFF" (failure to do so could result in damage to the solenoid coil). Remove the solenoid operator from the valve and remove the EL-128-A cartridge. Clean and/or repair as necessary.

INDICATOR: The red light stops flashing when user steps away but the valve does NOT make a "clicking" sound and does NOT flush.

CAUSE: EL-163-A solenoid shaft assembly is fouled or jammed.

SOLUTION: Turn electronic power to valve "OFF" (failure to do so could result in damage to the solenoid coil). Remove EL-101 or EL-166 nut from the solenoid operator. Remove the coil from the solenoid operator. Use a spanner wrench or pliers to remove the EL-163-A solenoid shaft assembly from valve. Clean and/or replace as necessary. Be sure to replace plunger spring when reassembling Solenoid Shaft Assembly.

INDICATOR: The red light flashes three (3) short flashes, three (3) long flashes then three (3) short flashes ("S-O-S") and continues to repeat this cycle even when user steps out of the sensor's detection range.

CAUSE: EL-1500-L Sensor wiring connections are incorrect.

SOLUTION: Rewire Sensor to valve. One solenoid lead connects to the "TO VALVE" connection on Sensor. One transformer lead connects to the "24 VAC IN" connection on Sensor. Second solenoid lead and second transformer lead connect together.

CAUSE: Wiring to Sensor is ground shorted.

SOLUTION: Find short in wiring circuit and correct.

CAUSE: EL-165-2 solenoid coil is burnt out or coil is not connected to solenoid plunger shaft.

SOLUTION: Reinstall or replace coil as necessary.

3. PROBLEM: Volume of water is insufficient to adequately siphon fixture.

CAUSE: Control Stop is not open wide enough.

SOLUTION: Adjust control stop for desired water delivery.

CAUSE: Low Consumption unit is installed on Water Saver or Conventional fixture.

SOLUTION: Replace Diaphragm component parts of valve with kit that corresponds to appropriate flush volume of fixture.

CAUSE: Inadequate water volume or pressure available from supply.

SOLUTION: Increase pressure or supply (flow rate) to the valve. Consult factory for assistance.

4. PROBLEM: Length of flush is too long (long flushing) or valve fails to shut off.

CAUSE: Water Saver valve is installed on Low Consumption fixture.

SOLUTION: Replace Diaphragm component parts of valve with kit that corresponds to appropriate flush volume of fixture.

CAUSE: Relief valve in diaphragm is not seated properly or bypass hole in diaphragm is clogged.

SOLUTION: Disassemble inside Diaphragm component parts and wash parts thoroughly. Replace worn parts if necessary.

5. PROBLEM: Water splashes from fixture.

CAUSE: Supply flow rate is more than necessary.

SOLUTION: Adjust Control Stop to meet flow rate required for proper cleansing of the fixture.

If further assistance is required, please contact Sloan Valve Company Installation Engineering Department at:

1-888-SLOAN-14 (1-888-756-2614).

PARTS LIST

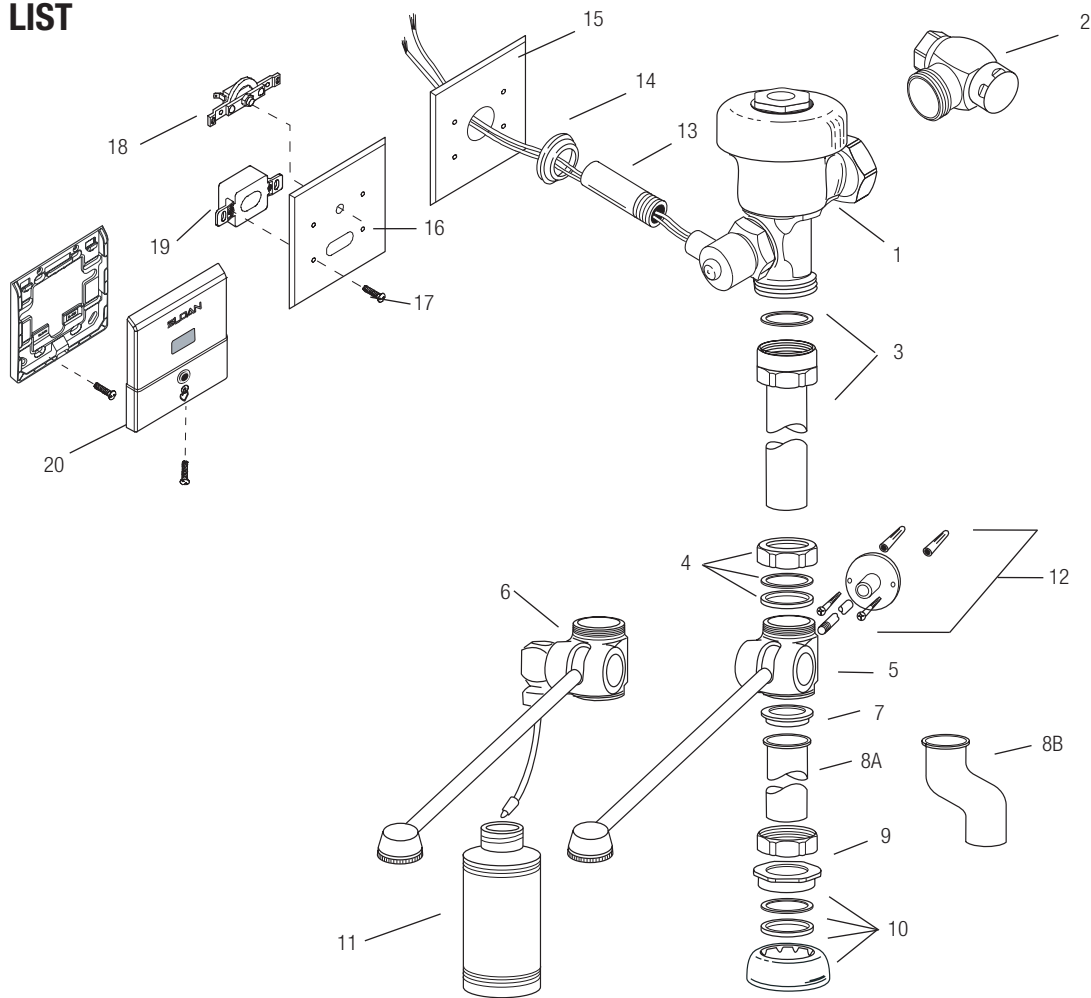

Item No.	Part No.	Description
1	†	Solenoid Activated Valve Assembly
2	H-700-A ‡	Bak-Chek® Control Stop
3	V-600-AA	Vacuum Breaker Assembly
4	F-2-A	1-1/2" Slip Joint Coupling
5	—	Diverter Valve Assembly without Deoseptic Unit
6	—	Diverter Valve Assembly with Deoseptic Unit
7	F-1003	Tube Gasket
8A	F-1005	1-1/2" Flanged Outlet Tube
8B	F-182	1-1/2" Flanged Outlet Tube with 1-1/2" Offset
9	F-2	1-1/2" Coupling Nut
10	F-5-A	1-1/2" Spud Coupling Assembly
11	DV-29	Deoseptic Bottle
12	DV-1001-A	Wall Support Kit
13	F-15	Tail Assembly
14	EL-431-A	Flange Assembly
15	HY-66	Cover Plate
16	EL-201	Cover Plate
17	EL-152	Screw (4 Required per Plate)
18	EL-141-A	Yoke and Override Button Assembly
19	EL-1500-L	Closet Sensor
20	EL-595A	Royal Closet Sensor

† Part number varies with valve model variation; consult factory.

‡ Length varies with valve model variation; consult factory.

For a complete listing of Flushometer Valve components and Repair Kits, see one of our Maintenance Guides or consult your nearest Plumbing Wholesaler.

When assistance is required, please contact Sloan Valve Company Installation Engineering Department at:

1-888-SLOAN-14 (1-888-756-2614) OR 1-847-233-2016

NOTICE: The information contained in this document is subject to change without notice.

SLOAN®

Water Connects Us™

Copyright © 2020 SLOAN VALVE COMPANY

SLOAN VALVE COMPANY • 10500 Seymour Avenue • Franklin Park, IL 60131
 Phone: 1-800-982-5839 or 1-847-671-4300 • Fax: 1-800-447-8329 or 1-847-671-4380
 sloan.com

Code No. 0816730 Rev. 1

(08/20)