

**NÚMERO DE CÓDIGO**

3346091

**DESCRIPCIÓN**

Sloan® Deck-Mounted Foam Soap Dispenser, Polished Chrome Finish

**DETALLES**

- Acabado: Polished Chrome (CP)
- Tipo de Energía: Turbina
- Altura: 4" (102mm)
- Anchura: 2" (51mm)
- Profundidad: 5 1/8" (132mm)
- Maximum Deck Thickness: 2" (51mm)
- Tipo de Sensor: IR

**CARACTERÍSTICAS**

Sensor Activated, Electronic, Chrome Plated Die Cast Body, Hand Washing Foam Soap Dispenser with the following features:

- Modular one-piece construction easily attaches to deck surface
- All electronics in spout are sealed
- Designed for drip free foam dispensing operation
- Motor Assembly suspended under counter connected to soap dispenser spout
- Motor Assembly rotates 360 degrees for easy installation
- Battery life of 45,000 activations
- 1,500 dispenses per foam soap bottle
- Ships with 2 bottles of non-scented, non-colored foam soap (1500ml per bottle)
- Additional foam soap can be purchased through Sloan (ESD-325) or GOJO distribution (8565-04-N6300GN)
- Ships with battery pack (4 "D" Alkaline batteries included)
- Sensor range - nominal 5"
- GFI outlet suggested per code
- 120V/15 Amp
- Optional AC adaptor can be purchased separately (part number 0346090)
- Select the ESD-601 to combine ESD-600 soap dispenser, 2 bottles of soap and the EBF-615-4 faucet

**SOAP REFILLS**

- ESD-325 (1500 ml/mL)

**VIDEOS**

- ▶ PVD Special Finishes

**CUMPLIMIENTOS Y CERTIFICACIONES**

(Cumplen con la Ley ADA, WELL Building Standard)

**ESPECIFICACIÓN RECOMENDADA**

Sloan Foam Soap Dispenser model number ESD-600. Chrome Plated Dispenser. Supplied with 2 bottles of 1500ml soap.

**DESCARGAS**

- [ESD Series Installation Instructions](#)
- [ESD-500/600/700/800/1500/2000/2100 Repair and Maintenance Guide](#)
- [Descargas Adicionales](#)

**NOTAS**

Toda la información contenida dentro de este documento está sujeta a cambio sin previo aviso.

**GARANTÍA**[View Warranty Information](#)



Sloan 10500 Seymour Ave, Franklin Park, IL 60131

Teléfono: 800.982.5839 • Fax: 800.447.8329 • [sloan.com](http://sloan.com)

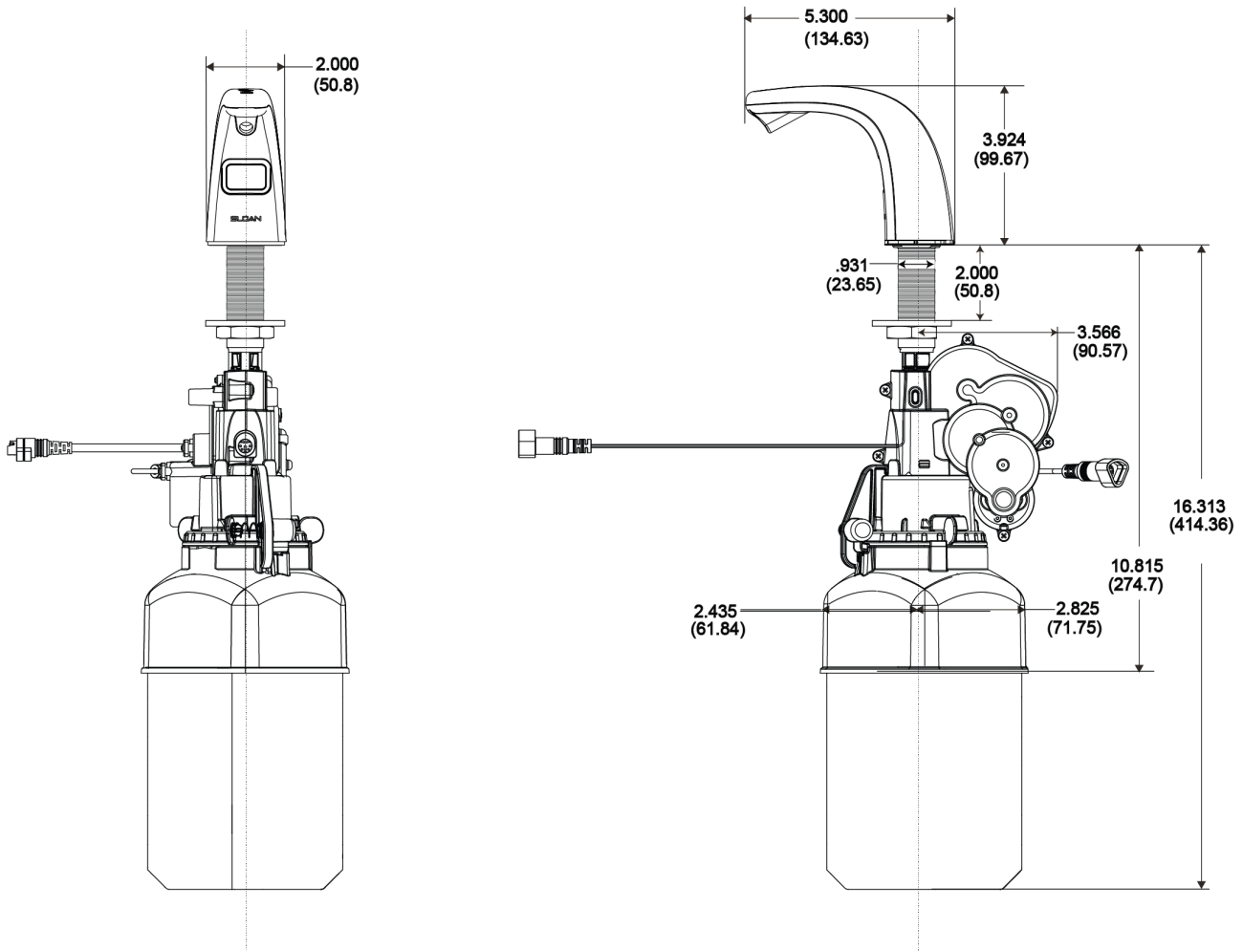
**PREPARACIÓN**



**LLAVES QUE HACEN JUEGO**

Name	Descripción	
 ETF-610	Optima® Cableado-Energizado Cubierta-Montado Bajo Cuerpo Llave	<a href="#">Ver más información</a>
 EBF-615	Optima® Baterías-Energizado Cubierta-Montado Bajo Cuerpo Llave	<a href="#">Ver más información</a>
 EBF-625	Optima® Battery or Turbine-Powered Deck-Mounted Low Body BAA Compliant	<a href="#">Ver más información</a>

**Sloan 10500 Seymour Ave, Franklin Park, IL 60131**  
Teléfono: 800.982.5839 • Fax: 800.447.8329 • [sloan.com](http://sloan.com)