

Naval® Flushometer

Also for use with Crown® (Old style),
Star and Marine

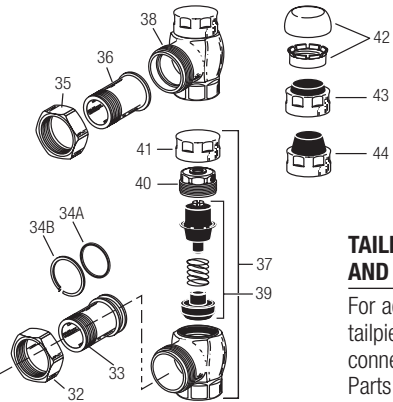
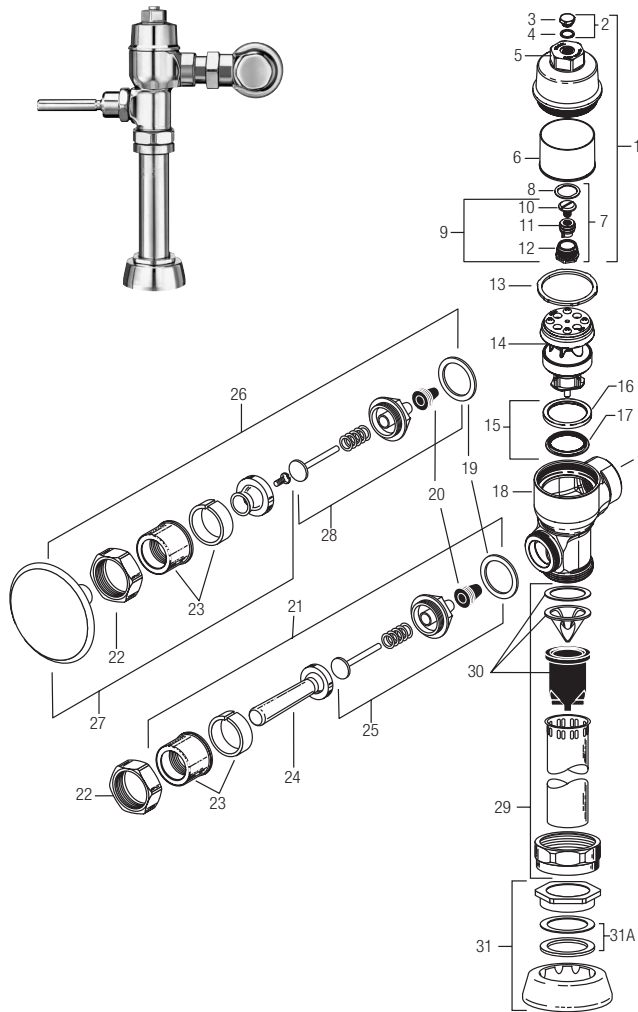

TAILPIECES, CONTROL STOPS, AND FLUSH CONNECTION'S

For additional information on tailpieces, control stops and flush connections see Showerhead's, Parts and Accessories Tab.

PARTS LIST

Item No.	Code No.	Part No.	Description
1.	0314229	CN-86-A	Cover Assembly CP
	0314310	CN-89-A	Cover Assembly CP One Pint* 1.6 gpf/6.0 Lpf, 1.0 gpf/3.8 Lpf
2.	5314010	CN-1007-A	Cap Screw Repair Kit – 6 per package
3.	—	CN-36	Cover Screw CP (included in item no.2)
4.	—	CN-30	Cover Screw Gasket (included in item no.2)
5.	—	CN-84	Cover (included in item no.1)
6.	—	CN-55	Cover Liner (included in item no.1)
7.	3314015	CN-1008-A	Regulating Screw Repair Kit**
8.	—	CN-81	Volume Adjustment Gasket (included in items no.1&7)
9.	0314315	CN-88-A	Low Consumption Volume Adjustment Sleeve Sub-Assembly 1.6 gpf/6.0 Lpf, 1.0 gpf/3.8 Lpf
10.	—	CN-80	Volume Adjustment Screw (included in items no.1&9)
11.	—	CN-78	Volume Adjustment Sleeve (included in item no.1)
	0314307	CN-87	Volume Adjustment Sleeve One Pint***
12.	0314301	CN-79	Volume Adjustment Housing
13.	5314243	CN-76	Cover Gasket – 12 per package
14.	0314016	CN-1002-A	Piston – Closet
	0314017	CN-1003-A	Piston – Urinal
15.	0314234PK	CN-21-A	Main Seat Assembly
16.	—	CN-111-A	Main Seat (included in items no.15)
17.	—	CN-113	Main Seat Ring (included in items no.15)
18.	0314020PK	CN-3	Body CP (less/Tailpiece)
19.	5301139	A-31	Handle Gasket – 48 per package

Item No.	Code No.	Part No.	Description
20.	5302297	B-39	Handle Seal – 12 per package
21.	3302002	B-73-A	Triple Seal Handicap Handle Assembly (ADA Compliant)
22.	0301082PK	A-6	Handle Coupling CP
23.	0302109	B-7-A	Socket Assembly CP
24.	0302389PK	B-74-A	Handicap Handle Grip CP (ADA Compliant)
25.	3302306	B-51-A	Triple Seal Handle Repair Kit – 1 per package
26.	0303351	C-42-A	3" Push Button Assembly CP
27.	3303347	C-1000-A	3" Push Button Replacement Kit
28.	3303396	C-64-A	3" Push Button Repair Kit
29.	5323005	V-500-AA	3/4" x 9" Vacuum Breaker
	5323006	V-500-AA	1-1/4" x 9" Vacuum Breaker
	5323007	V-500-AA	1-1/2" x 9" Vacuum Breaker
30.	3323192	V-551-A	Vacuum Breaker Repair Kit
31.	0306125	F-5-AW	3/4" Spud Coupling CP
	0306140	F-5-AU	1-1/4" Spud Coupling CP
	0306146	F-5-AT	1-1/2" Spud Coupling CP
31A.	SEE SLIP JOINT GASKETS AND RINGS TABLE ON BOTTOM, PAGE 43		
32.	0308676PK	H-550	Stop Coupling CP
33.	0314289	NH-551-A	Adjustable Tailpiece 2-1/16" CP
34A.	5308696	H-553	O-ring – 24 per package
34B.	5308381	H-552	Locking ring – 12 per package
35.	0308063PK	H-6	Ground Joint Stop Coupling CP
36.	0314028PK	NH-5	Ground Joint Tailpiece 1-5/8"
37.	0388022	H-710-A	1" Adjustable Tailpiece SD Bak-Chek® Control Stop CP
	0388025	H-710-A	3/4" Adjustable Tailpiece SD Bak-Chek® Control Stop CP
38.	0388024	H-710-AG	1" Ground Joint Screwdriver Bak-Chek® Control Stop CP
	0388026	H-710-AG	3/4" Ground Joint Screwdriver Bak-Chek® Control Stop CP
39.	3308853	H-541-A	Control Stop Repair Kit †
	3308856	H-543-A	Control Stop Repair Kit †
40.	0308612	H-622PK	Bonnet CP †
	0308843	H-577	Bonnet CP † – DISCONTINUED
41.	3308840	H-573	Control Stop Cap CP †
	0308848PK	H-582	Control Stop Cap CP †
42.	3308772	H-1010-A	Vandal Resistant Stop Cap Assembly †
	3308790	H-1009-A	Vandal Resistant Stop Cap Assembly †
43.	3308866	H-574	Control Stop Cap with Bumper† (YO Variation)
44.	3308867	H-576	Control Stop Cap with Extended Bumper† (YG Variation)

* Use CN-89-A Cover Assembly One-Pint for reduced flush volumes 1.6 gpf/6.0 Lpf, 1.0 gpf/3.8 Lpf
 ** CN-1008-A Regulating Screw Repair Kit contains the parts shown plus the parts for old style adjusting screw as currently shown on the repair guide (CN-24, CN-25, CN-26, CN-61)
 *** Use CN-87 Volume Adjustment Sleeve One-Pint for reduced flush volumes
 † For use with 1" and 3/4" H-740-A-CP (less cap) and 1" H-540-A-CP (w/H-37 cap) Bak-Chek® screwdriver control stops
 ‡ For use with 3/4" H-600 Series Bak-Chek® screwdriver control stops

Naval® Flushometer

Also for use with Crown® (Old style),
Star and Marine

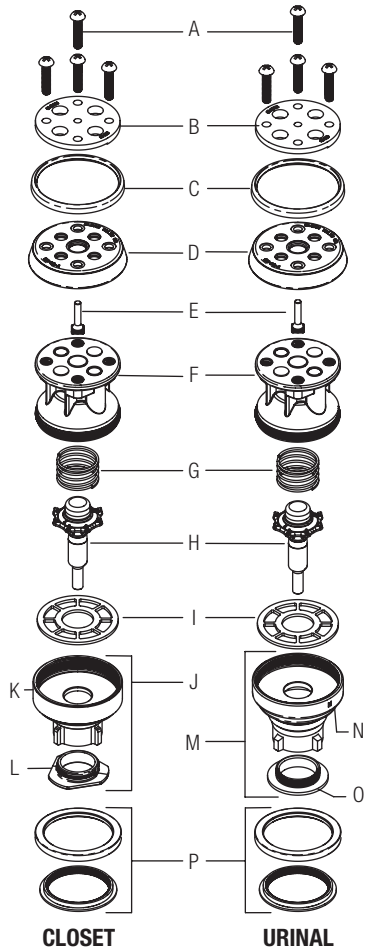

NAVAL PISTON COMPONENTS (Items 14 thru 17 on previous page)

Item	Code No.	Part No.	Description
A.	5314200	CN-17	Top Plate Screws – 24 per package
B.	0314082PK	CN-15	Top Plate
	0314179PK	CN-15-A	Top Plate – Shower Valve only
C.	0314314	CN-92	Support Cup Lip Seal
			Part of CN-1015-A (3314003)
D.	5314188	CN-68-A	Single Lip Cup – 12 per package
E.	0314204PK	CN-57	Xpelor
F.	0314228	CN-160	Piston Body
G.	5328019	SH-406	Spring – 12 per package (Replaces S/CN-58 Safety Bar)
H.	0314078	CN-18-A	Relief Valve
I.	5314226	CN-120	Relief Valve Seat – 12 per package
J.	0314240	CN-123-AC	Guide Assembly – Closet
K.	0314231	CN-23	Guide – Closet
L.	0314237	CN-144	Restriction Ring – Closet (included in item J)
M.	0314242	CN-123-AU	Guide Assembly – Urinal
N.	0314189	CN-43	RC Guide – Urinal (included in item M)
O.	—	CN-45	NK Restriction Ring – Urinal (included in item M)
P.	0314234PK	CN-21-A	Main Seat
	0314223PK	CN-121-A	Main Seat – Shower Valve only

NOTE: Naval® pistons can be used to replace pistons in older Crown® and Star flushometers.

REPAIR KITS

Code No.	Part No.	Description
0314016	CN-1002-A	Piston with Main Seat – Closet
0314017	CN-1003-A	Piston with Main Seat – Urinal
5314094	CN-1004-A	Piston Rebuild Kit – Closet & Urinal – 6 per package includes: 13, A, B, C, D, E, I, K, Cap Screw Gasket & Regulating Screw Packing
5314184	CN-1006-A	Piston Rebuild Kit – Shower – 6 per package includes: 13, A, B, C, D, E, I, K, Cap Screw Gasket & Regulating Screw Packing
3314015	CN-1008-A	Regulating Screw Repair Kit – includes: 2, 8, 9, CN-24 Packing Disc, CN-25 Packing Gland, CN-26 Packing Regulating Screw, CN-61 Screw Regulating Stable Piston
0314191	CN-1009-A	Piston with Main Seat – Shower
5314050	CN-1010-A	Crown®/Naval® Valve Washer Set – 6 per package includes: 13, 19, 20, C, D, I, K, Cap Screw Gasket & Regulating Screw Packing
5319049	S-14-AA	Double Cup Repair Kit (Old style Crown, Star and Marine)
5319046	S-14-A	Double Cup Lip Seal only (Old style Crown, Star and Marine)

NOTE: Older Crown® pistons need S-14-A W/CN-1002, 1003 & 1009 if replacing piston.

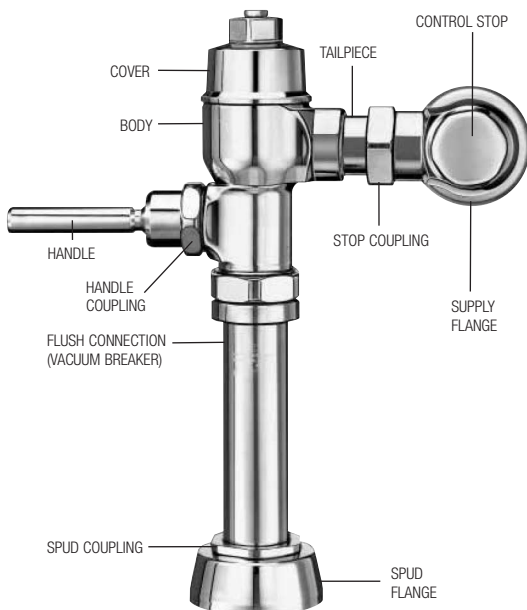

ITEM 31A. SLIP JOINT GASKETS AND RINGS

Size	Code No.	Part No.	Description
1-1/2"	5306058	F-3	Red Friction Ring
	5322001	VBF-5	Black Slip Joint Gasket
	5319086	S-30	Flexible Seat
	0319079	S-21	Rigid Seat (rubber over brass)
1-1/2" x 1-1/4"	0396062	F-105	Slip Joint Gasket – Rigid
1-1/4"	5306057	F-3	Red Friction Ring
	5322176	VBF-5	Black Slip Joint Gasket
	0307052/5307052	G-21	Rigid Seat (rubber over brass)
1"	5306056	F-3	Red Friction Ring
	5306115	F-5	Black Slip Joint Gasket
3/4"	5306055	F-3	Red Friction Ring
	5306113	F-5	Black Slip Joint Gasket

Naval® Flushometer

Also for use with Crown® (Old style),
Star and Marine

TROUBLESHOOTING GUIDE

IMPORTANT: The NAVAL® flushometer is engineered for quiet operation. Excessive water flow creates noise, while too little water flow may not satisfy the needs of the fixture. Proper adjustment is made when plumbing fixture is cleansed after each flush without splashing water out from the lip AND a quiet flushing cycle is achieved.

Never open Control Stop to where the flow from the valve exceeds the flow capability of the fixture. In the event of a valve failure, the fixture must be able to accommodate a continuous flow from the valve.

ATTENTION INSTALLERS: With the exception of the control stop inlet, DO NOT USE pipe sealant or plumbing grease on any valve component or coupling! To protect the chrome or special finish of Sloan flushometers, DO NOT USE toothed tools to install or service these valves. Use our A-50 Super-Wrench™ or other smooth-jawed wrench to secure couplings. Regulations for low consumption fixtures (1.6 gpf/6.0 Lpf closets and 1.0 gpf/3.8 Lpf urinals) prohibit use of higher flush volumes.

NOTE: In all piston variations the SH-406 spring has replaced the "U" bar. In all piston variations the CN-68-A single lip cup has replaced the S-14-A double lip cup. When rebuilding a piston, install the CN-68-A single lip cup with the cup facing down.

1. Valve DOES NOT function.

- A. Control stop or main valve closed. Open control stop or main valve.
- B. Handle assembly is worn. Install handle repair kit B-51-A or replace handle.

2. Insufficient volume of water to adequately siphon fixture.

- A. Control stop not open enough. Adjust control stop for desired delivery of water.
- B. Urinal or shower piston installed in a closet valve or older blow out urinal. Replace piston with proper closet piston (see item 4).
- C. Regulating screw (on top of valve) not at proper setting. Turn regulating screw counterclockwise to increase flush. Adjustment range: urinal – 0.5 to 3 gpf (1.9 to 11.4 Lpf); closet – 1.5 to 7 gpf (5.7 to 26.5 Lpf).
- D. Piston worn out. Repair or replace piston.
- E. Inadequate volume or pressure at supply. If no gauges are available to properly measure supply pressure or volume of water at the valve, then completely remove the entire piston from the valve, reassemble cover and open control stop to allow water to pass through empty valve. If the supply is adequate to siphon the fixture, remove the flow ring from the bottom of the piston to provide additional flow. If the supply is not adequate to siphon the fixture, steps should be taken to increase the pressure and/or supply.

3. Length of flush too short (short flushing) or valve closes off immediately.

- A. Regulating screw not at a proper setting. Turn regulating screw counterclockwise to lengthen flush.
- B. Water passing by damaged or worn piston cup. Repair or replace piston.
- C. Loose piston assembly or loose top plate screw. Tighten top plate screws. Screw piston body and guide together (hand tighten ONLY – rubber relief valve seat will distort if screwed too tight).
- D. Damaged or worn piston top plate or expelor. Repair or replace piston.
- E. Urinal or shower piston installed in a closet valve or older blow out urinal. Replace piston with closet piston CN-1002-A.

4. Length of flush too long (long flushing) or fails to close off.

- A. Regulating screw not at proper setting. Turn regulating screw clockwise to shorten flush.
- B. Relief valve in piston is not seating properly due to wear or debris. Disassemble piston assembly and wash under running water. Repair or replace piston if necessary.
- C. Bypass holes in piston or top plate clogged or fouled with debris. Disassemble piston assembly and wash under running water. Repair or replace piston if necessary.
- D. Closet piston installed in urinal valve. Replace piston with urinal piston CN-1003-A.
- E. Line water pressure has dropped and is not sufficient to force relief valve to seat. Shut off control stop until pressure has been restored, then reopen stop.

5. Water splashes from fixture.

- A. Supply volume is more than necessary. Adjust control stop to meet flow rate required for proper cleansing of fixture.
- B. Lime or mineral accumulation on fixture vortex or spreader holes. Remove lime or mineral build-up in fixture.

6. Flush is not considered "quiet" or makes noise at close off.

- A. Control stop not properly adjusted. Adjust control stop to meet flow rate required for proper cleansing of the fixture.
- B. Worn, damaged or loose main seat. Replace main seat.
- C. Worn piston. Repair or replace piston.

7. Leaking at handle assembly.

- A. The B-39 handle seal may be deteriorated. Install new B-39 handle seal. NOTE: The B-39 seal will easily slide right onto the bushing if it is wet.
- B. Handle gasket has been omitted. Install A-31 handle gasket or handle repair kit B-51-A.
- C. Valve handle bushing is worn. Install handle repair kit B-51-A.

CARE AND CLEANING INSTRUCTIONS

DO NOT USE abrasive or chemical cleaners to clean flushometers that may dull the luster and attack the chrome or special decorative finishes. Use **ONLY** mild soap and water, then wipe dry with clean cloth or towel.

While cleaning the bathroom tile, protect the flushometer from any splattering of cleaner. Acids and cleaning fluids can discolor or remove chrome plating.

When assistance is required, please contact

Sloan Technical Support at: 1-888-SLOAN-14 (1-888-756-2614).